

TRINITY - a light and printable electric glider

Specifications

Wingspan:	2006 mm / 79"
Fuselage:	1218 mm / 48"
Flying Weight:	990 g / 35,2 oz
Wing loading:	27 g/ dm ²
Airfoil:	HQ/W-2,25/9
RC-functions:	Rudder / Elevator / Throttle

IMPORTANT - for slicing and printing this plane **CURA SLICER** is required

For more information please read this manual and visit www.printandfly.com

Thank you for choosing a lightweight *print&Fly* printable plane. We hope you will have fun and enjoy it.

Our *TRINITY* can be built in a pure glider version as well as powered electrically – this data includes all files you need for both versions.

May we ask you to read some remarks at the beginning? As we can say, It takes a lot of time to develop planes like this. After an intensive CAD-process of many, many hours, we have to prototype, testfly and improve every single component of a plane like this. This is one reason why we appeal to the fairness of all visitors and clients of *printandfly.com* to respect our work and not to share the printing-data in a way that disregards our mental ownership or might damage us in any other way. To prevent misuse of our data, they contain unerasable copyright watermarks, which qualify them as our development. Thank you and let us begin..

Most rc-pilots prefer planes with small wingload for comfortable flying characteristics, especially concerning thermal gliders – just as we do. But how can we achieve this with 3D-printed planes? This is the answer:

ONE-WALL-PRINTING BY USING LW-PLA

Please read following informations carefully to get good printing results. Before printing can begin, some special kind of onewall-3D-data are required. As a result of intensive designwork, we are able to offer those unique and sophisticated 3D-files, which allow rc-pilots to print and assemble very lightweight rc-planes such as our

TRINITY

As far as we know, the only slicing software that works for one-wall printing – available as free download – is

ULTIMAKER CURA

We are using Prusa-Printers and ColorFabb-LW-PLA to design our planes. Based on those printers and material, we create our CURA-printing-profiles as a proposal, **tested up to CURA-Version 5.10.1**, and offered on our homepage as free download. We recommend to use our profiles as basic, even if you work with other printers or LW-PLA from other manufacturers to figure out your individual settings by making tests and adjustments.

When opening our STL-files in CURA, the slicer sometimes shows a fault report – **PLEASE IGNORE** and **DO NOT** try to repair our STL-files – **They are watertight!**

► NOTICE FOLLOWING FEATURES

- use 0.4mm Nozzle
- use only LW-PLA, not HT-LW-PLA (except PLA for functional parts)
- Flow about 60% for optimal weight and strength
- Create Cura-profiles based on our suggestions - to be found as free-download on www.printandfly.com
- temperature about 230°-245°C (ColorFabb-LW-PLA) to reach good adhesion between layers
- cooling fan between 0-15% - better no cooling
- we submit to slice and print our free-download printandfly testing data

LW-PLA can not be replaced, not even by HT-LW-PLA!

► SLICING THE FUSELAGE - all fuselage and rudder segments must be printed in **LW-PLA**

- the following graphics are showing the fuselage segments in **CURA-X-Ray-View**
- use slicing profile **PriFI-onewall1**
- the single wall thickness of the printed parts should be 0.4-0.5 mm, depending on the temperature
- It is important to place the segments as shown in X-Ray-View. Don't rotate horizontal by use of x/y level!
- to avoid slicing errors, only one printing part is recommended on the buildplate, using this slicing profile
- brim can be helpful for better buildplate adhesion and surface quality – we use it up to 30 brim lines

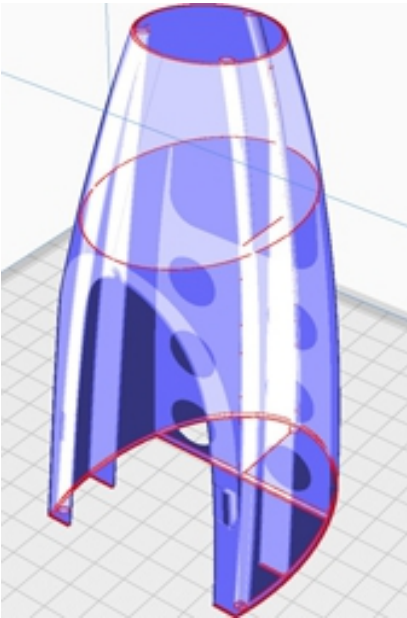

TRINITY_fuselage1_LWPLA.stl
- weight~35g -

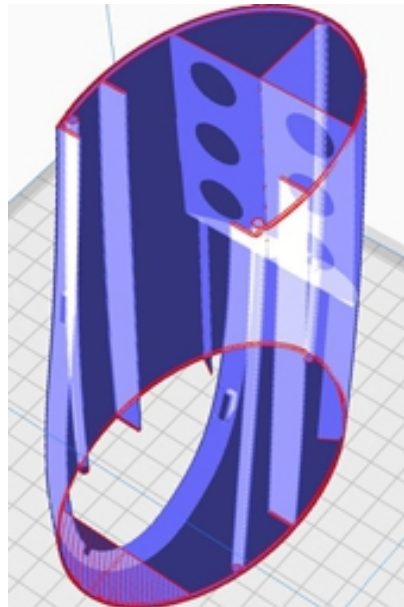

TRINITY_fuselage2_LWPLA.stl
- weight~38g -

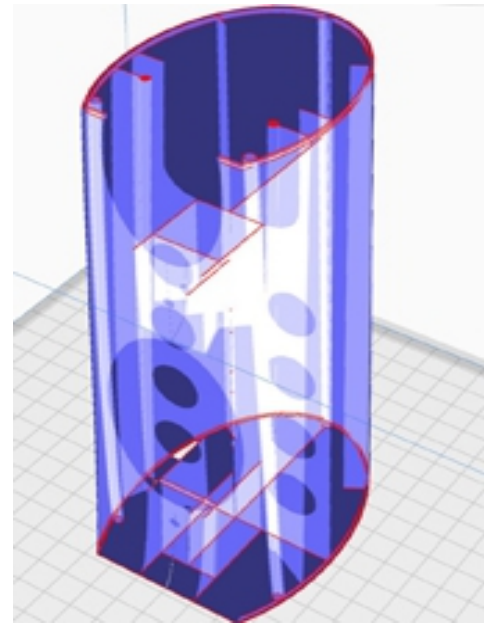

TRINITY_fuselage3_LWPLA.stl
- weight~48g -

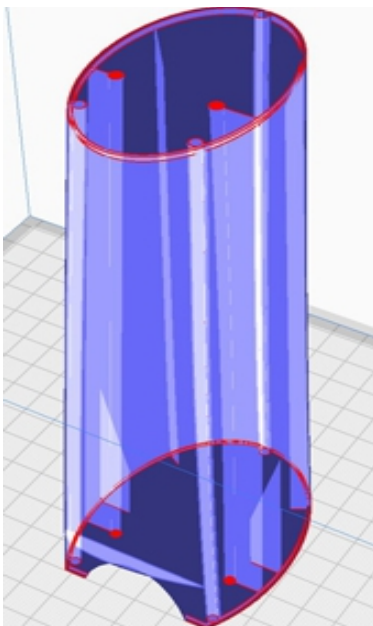

TRINITY_fuselage4_LWPLA.stl
- weight~30g -

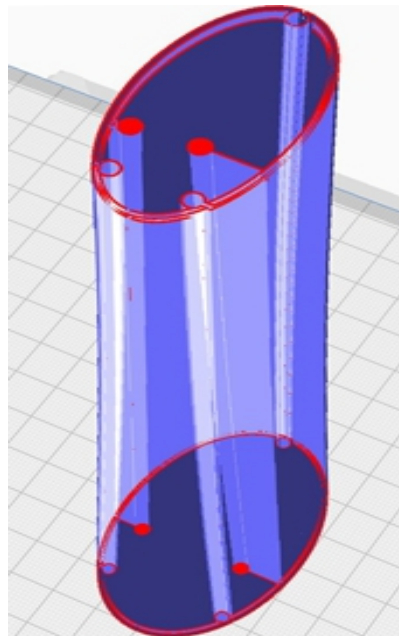

TRINITY_fuselage5_LWPLA.stl
- weight~20g -

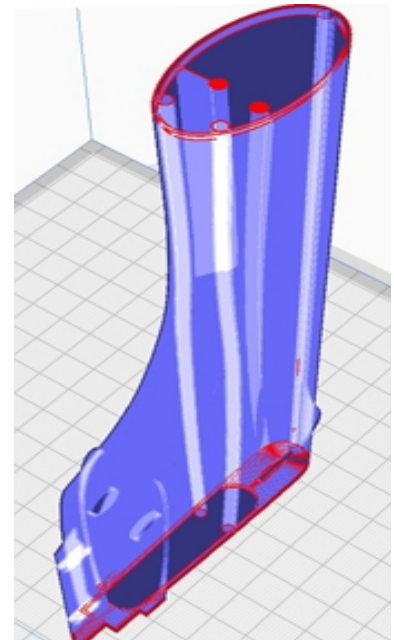

TRINITY_fuselage6_LWPLA.stl
- weight~22g -

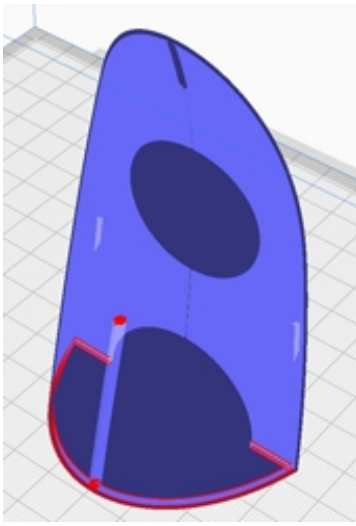

TRINITY_canopyfront_LWPLA.stl
- weight~6g -

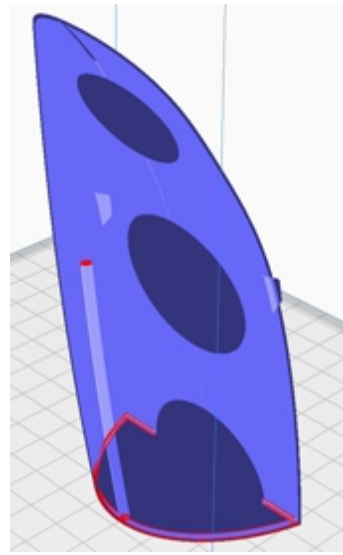

TRINITY_canopyrear_LWPLA.stl
- weight~10g -

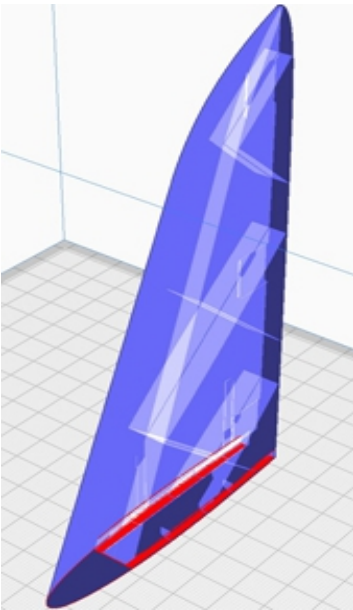

TRINITY_fuselagerudder_LWPLA.stl
- weight~13g -

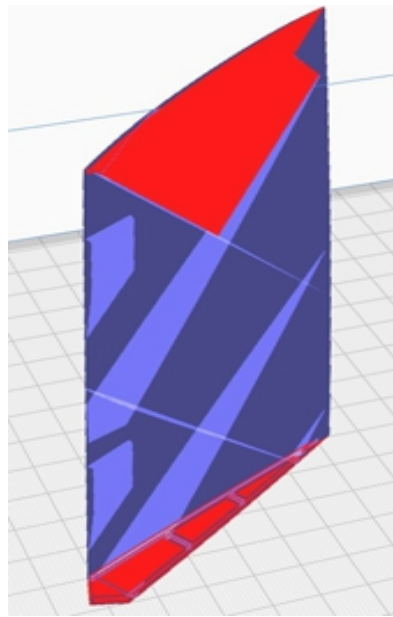

TRINITY_ruddertop_LWPLA.stl
- weight~6g -

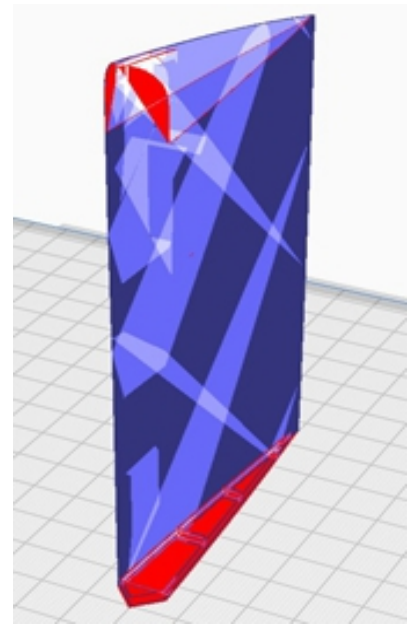

TRINITY_rudderbelow_LWPLA.stl
- weight~9g -

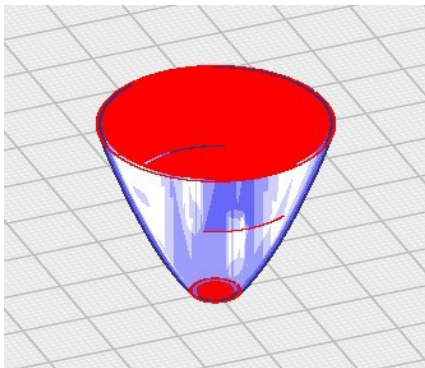

TRINITY_spinner_LWPLA.stl
optional - we recommend PLA-
Version, mentioned below

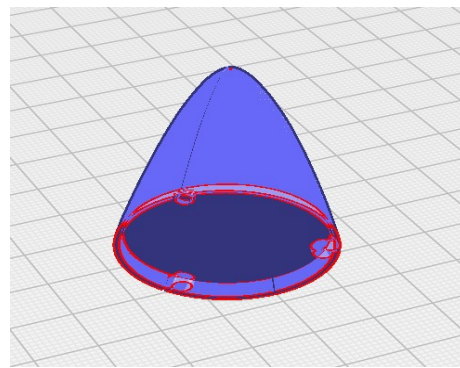

TRINITY_fuselagenose_LWPLA.stl
only needed for pure glider version

► **SLICING THE WING** - all wing segments must be printed in **LW-PLA**

- the following graphics are showing the right wing segments in **CURA-X-Ray-View**
- use slicing profile **PF-surface-A**.
- It is important to place the segments as shown in X-Ray-View. Don't rotate horizontal by use of x/y level!
- Best printing quality when printing begins on the wing-upperside. Z-axis rotation of wingpart can help.
- the single wall thickness of the printed parts should be 0.4-0.5 mm, depending on the temperature
- to avoid slicing errors, only one printing part is recommended on the buildplate, using this slicing profile
- brim can be helpful for better buildplate adhesion and surface quality – we use it up to 30 brim lines

NOTICE: THERE ARE WING SEGMENTS FOR THE RIGHT WING; CALLED `wingright.stl` AND WING SEGMENTS FOR THE LEFT WING; CALLED `wingleft.stl`

THE SAME FOR THE ELEVATOR, `elevatortright.stl` AND `elevatorleft.stl`.

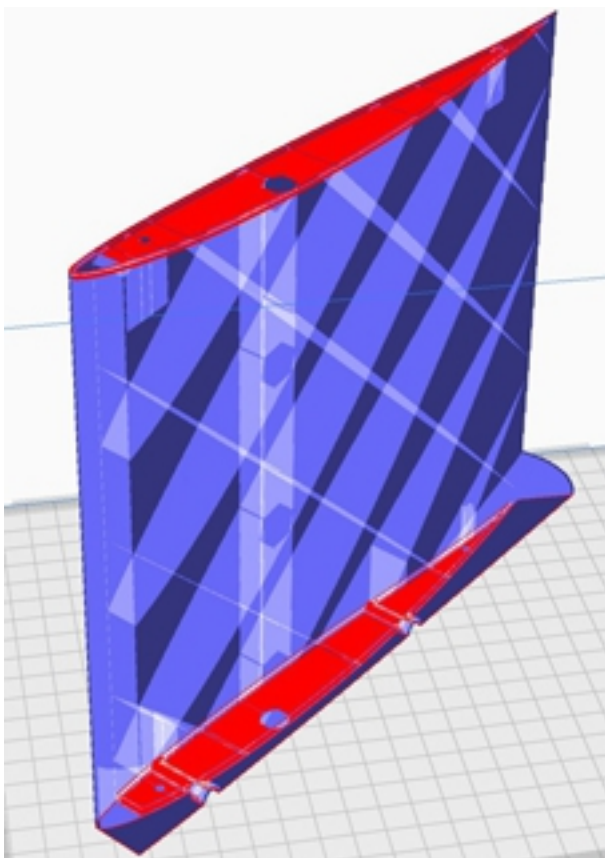

TRINITY_wingright1_LWPLA.stl
- weight~43g -

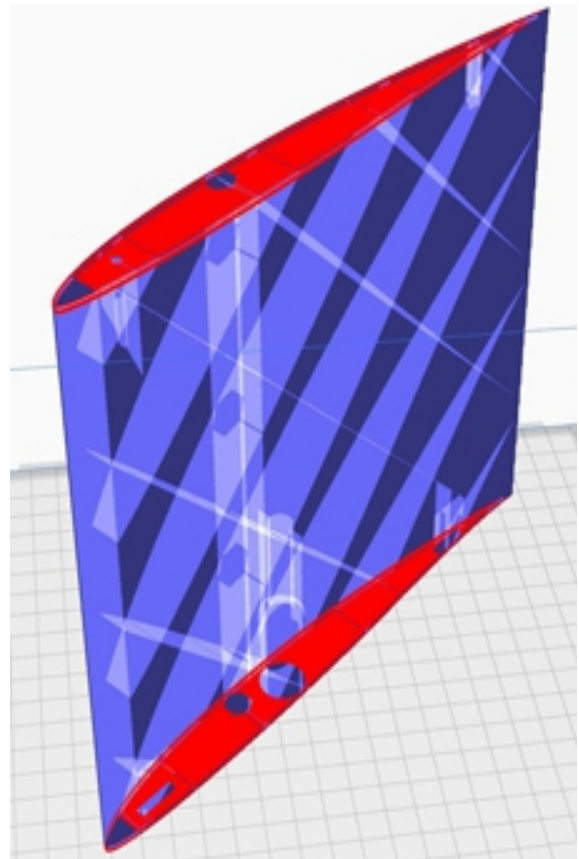

TRINITY_wingright2_LWPLA.stl
- weight~43g -

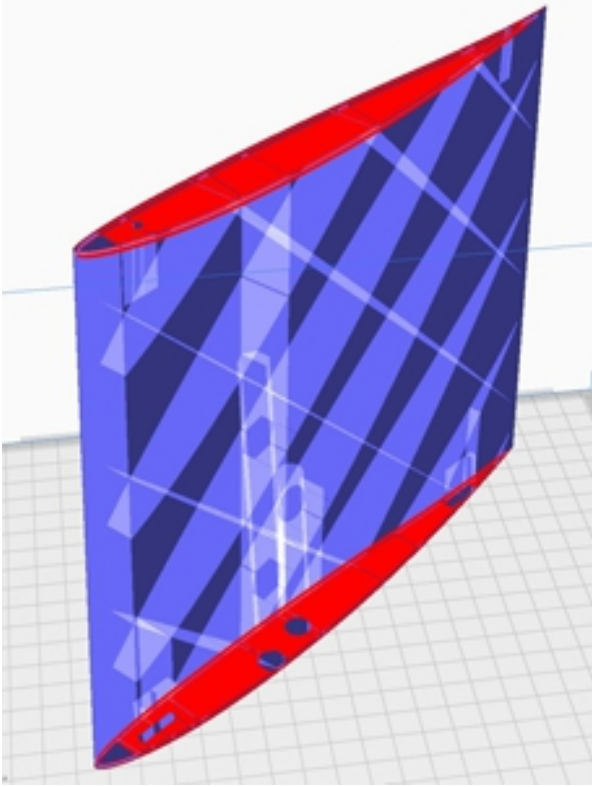

TRINITY_wingright3_LWPLA.stl
- weight~43g -

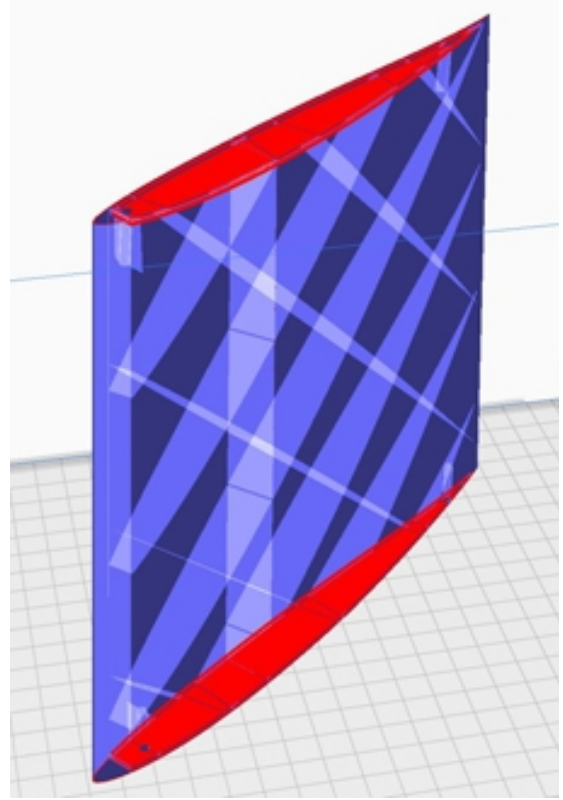

TRINITY_wingright4_LWPLA.stl
- weight~35g -

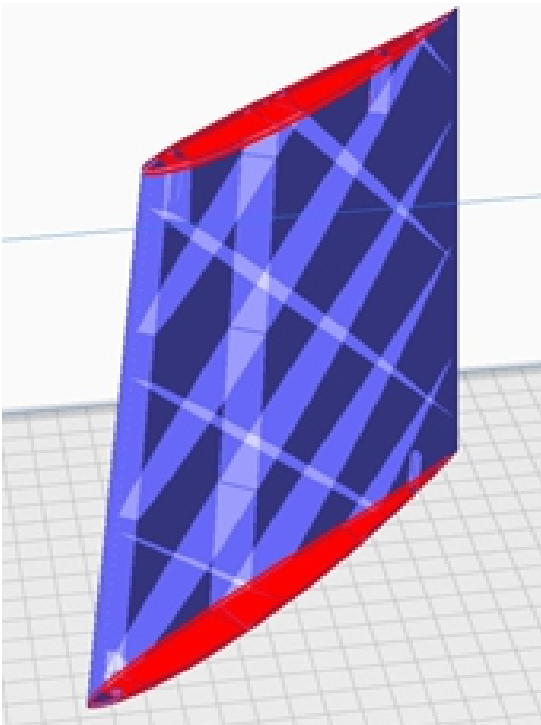

TRINITY_wingright5_LWPLA.stl
- weight~27g -

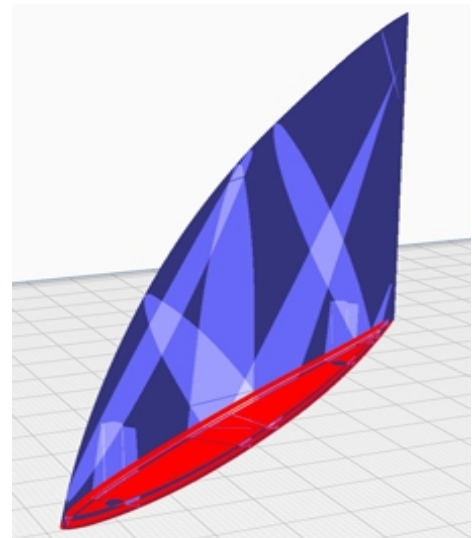

TRINITY_wingright6_LWPLA.stl
- weight~6g -

► SLICING THE ELEVATOR - all elevator segments must be printend in **LW-PLA**

- the following graphics are showing the right elevator segments in **CURA-X-Ray-View**
- use slicing profile **PF-surface-A**
- the single wall thickness of the printed parts should be 0.4-0.5 mm, depending on the temperature
- to avoid slicing errors, **only one** printing part is recommended on the buildplate, using this slicing profile
- brim can be helpful for better buildplate adhesion and surface quality – we use it up to 30 brim lines

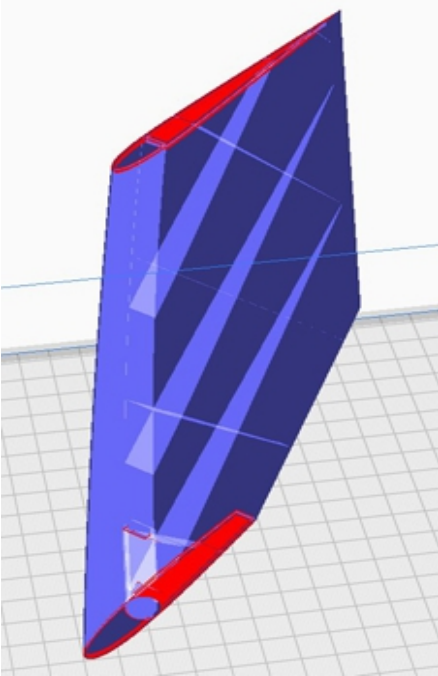

TRINITY_elevatortright1_LWPLA.stl
- weight~19g -

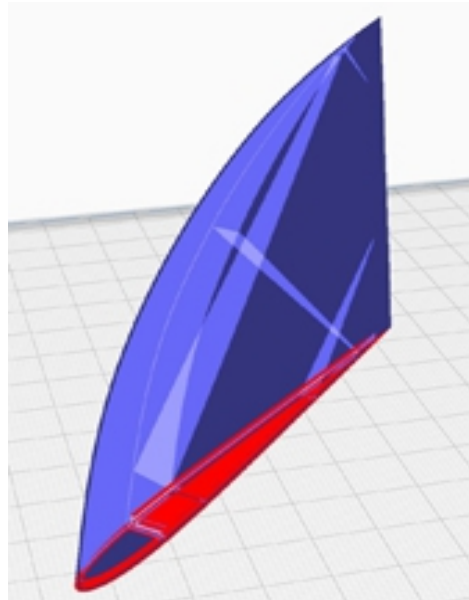

TRINITY_elevatortright2_LWPLA.stl
- weight~5g -

► SLICING THE FUNCTIONAL PARTS - all functional parts must be printend in **PLA**

- the following graphics are showing the functional parts in **CURA Layer View**
- use slicing profile **PriFI-volume1**
- brim can be helpful for better buildplate adhesion
- Spinner needs Support – we suppose >Tree-structure< as printing support

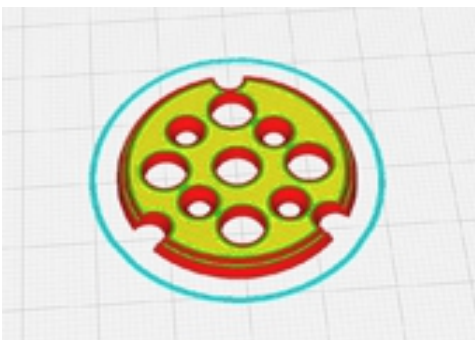

TRINITY_motormount_PLA.stl

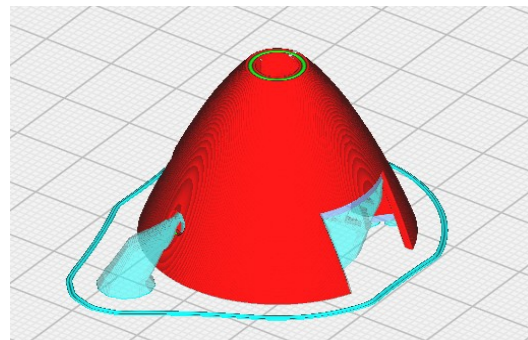

TRINITY_spinner_PLA.stl

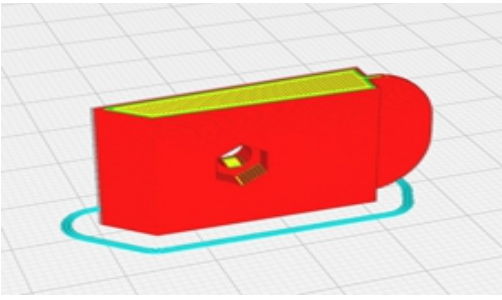

TRINITY_fuselagescrewrear_PLA.stl

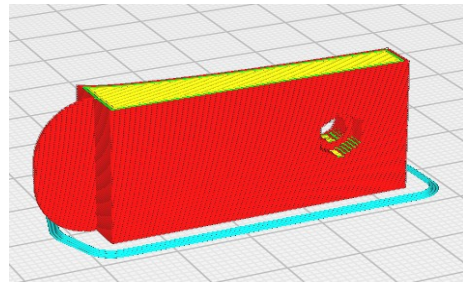

TRINITY_fuselagescrewfront_PLA.stl

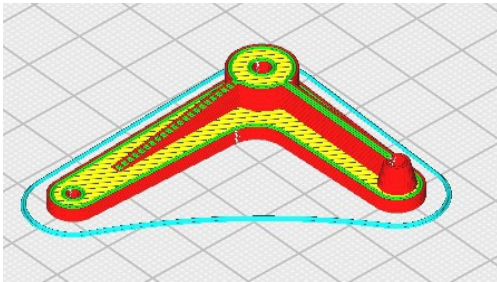

TRINITY_elevatorlever_PLA.stl

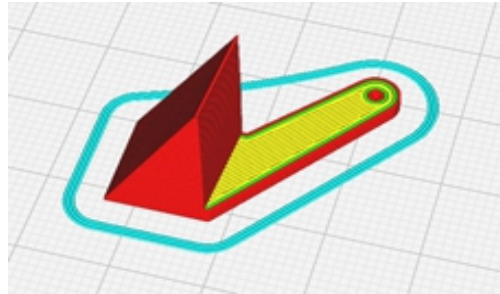

TRINITY_rudderlever_PLA.stl

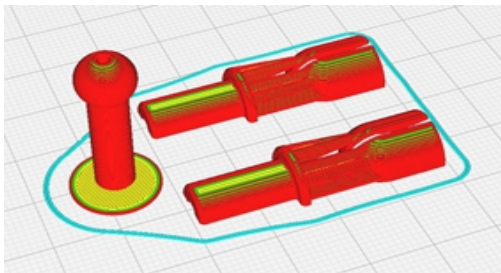

TRINITY_wingquicklock_PLA.stl

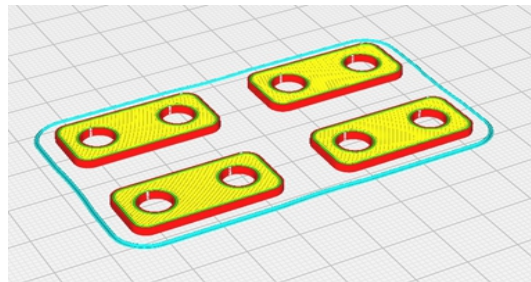

TRINITY_wingpin_PLA.stl

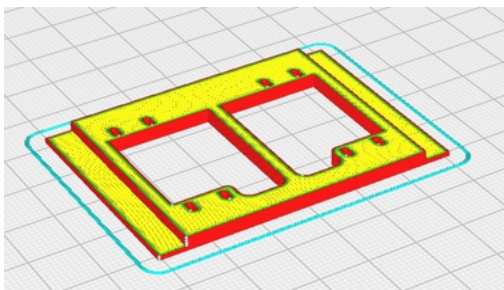

TRINITY_servomount_PLA.stl

Grey / Blue / Black = LW-PLA

Red = PLA

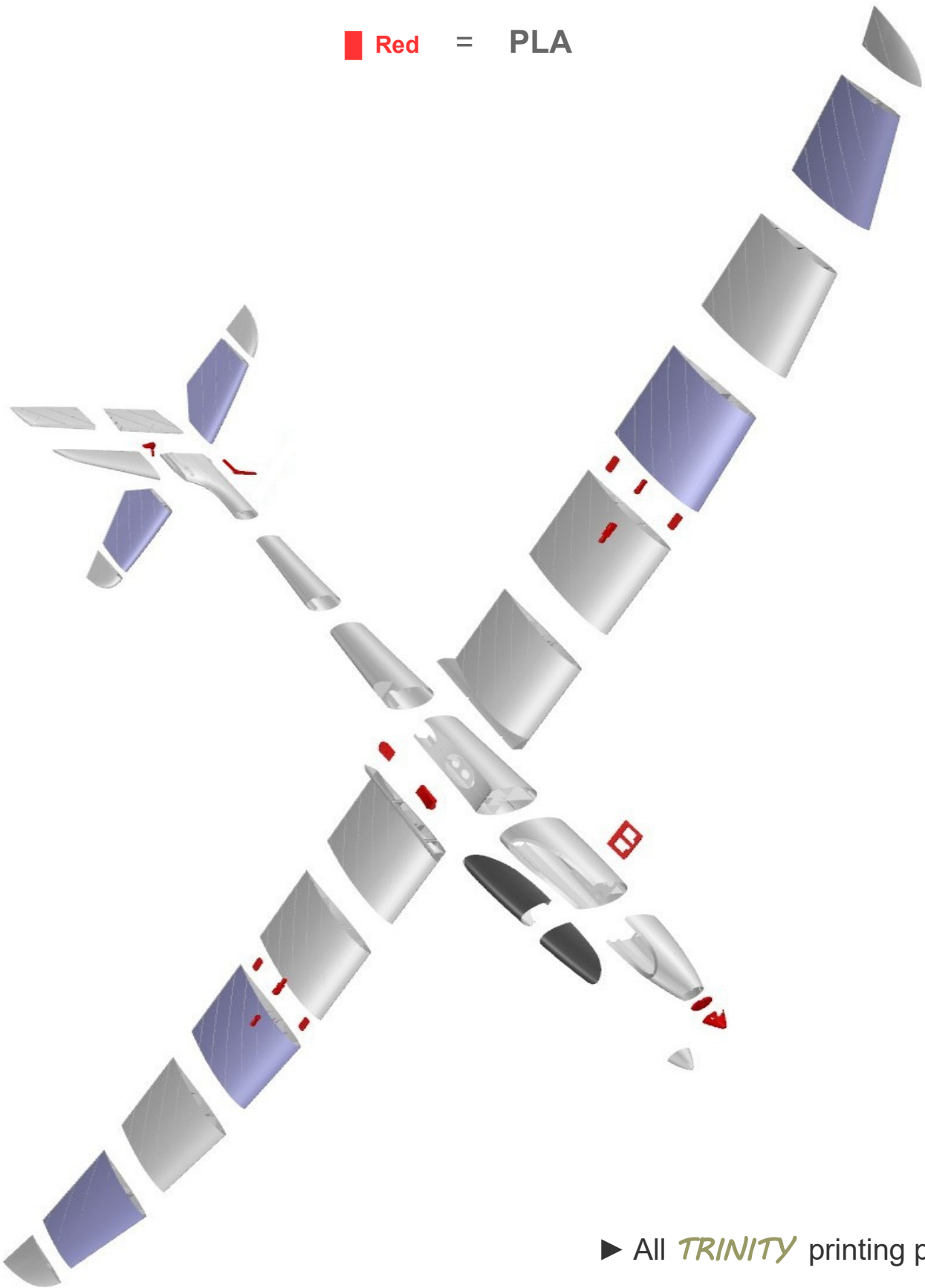

► All *TRINITY* printing parts

BUILDING THE PLANE - after slicing and printing let's start **ASSEMBLING THE PARTS**

Meanwhile, a lot of components should have been printed - which can now be cleaned and sanded, depending on your own ideas what kind of surface quality you want to achieve. LW-PLA ist easy to sand. We use 150-220 grit sandpaper to get good results – but sanding ist optional, except gluing areas, where it is advisable.

Some additional material will be needed to build the plane:

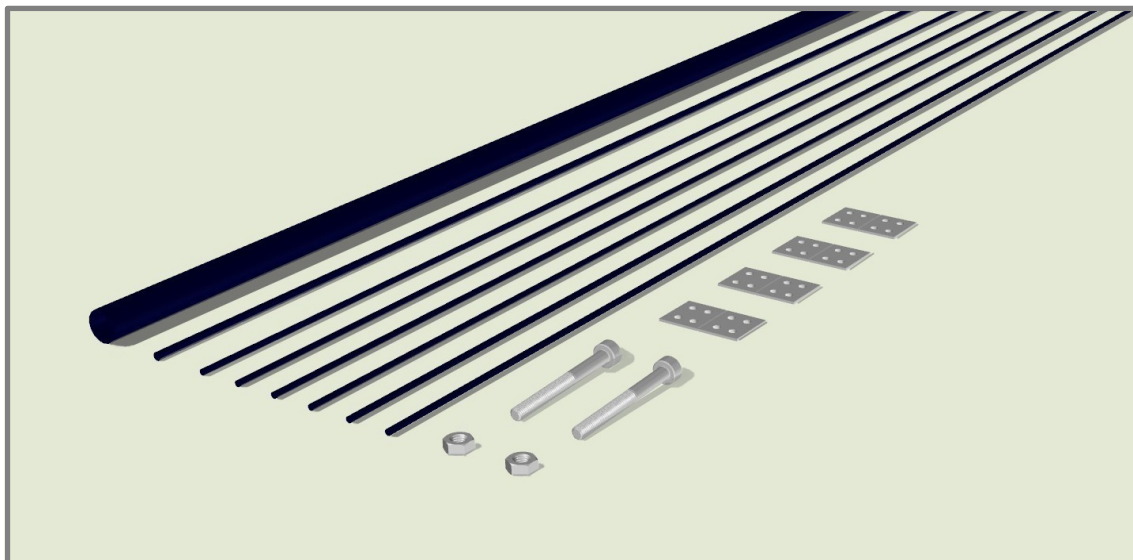

FUSELAGE-MATERIAL

- 6 x Carbon-Rod Ø1,5 x 1000mm
- 2 x M3 Nuts
- 4 x Film Hinges

WING / ELEVATOR-MATERIAL

- 1 x Carbon-tube Ø8x6 x1000mm
- 1 x Carbon-Rod Ø2 x1000mm
- 2 x M3x30-35mm Cylinder Head Screws

RC Equipment

- ▶ **Receiver** 2-3 Channel, depending on glider or motorized version
- ▶ **Servos** Two 12 x23mm (Width x Length) Servos
- ▶ **Motor** Brushless Outrunner, Ø28mm, frontside Installation
- ▶ **BEC-Controler** Compatible to the Motor
- ▶ **Folding Propeller** 10 x 4" (25,5 x 10cm) with Aluminium center hub 34-35mm
- ▶ **Spinner** Printable, or purchased Ø 36mm
- ▶ **Battery** 3S Lipo, about 1000 mAh

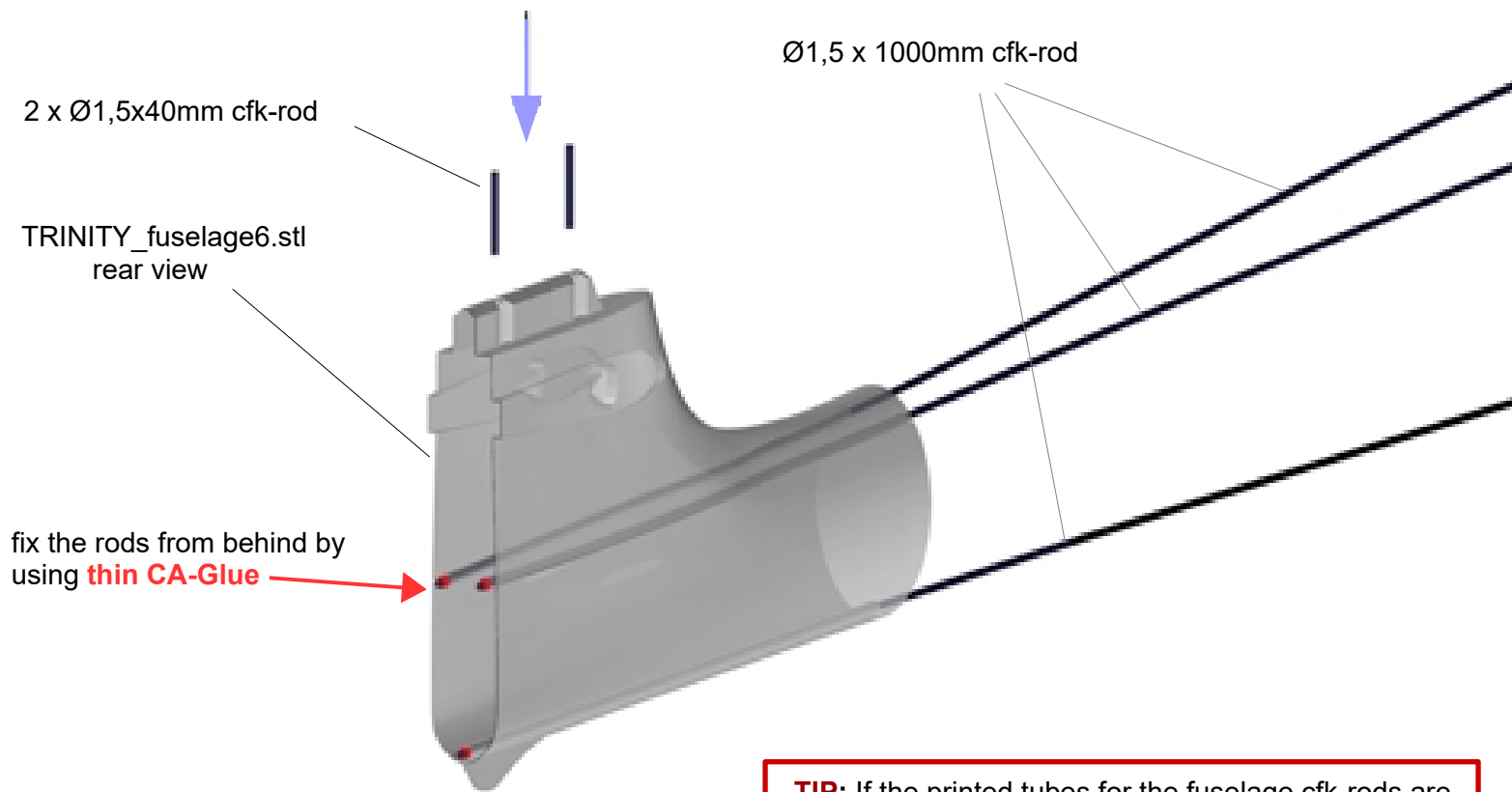

TIP: If the printed tubes for the fuselage cfk-rods are too tight, you can use a drill with a Ø1,5mm steel wire to carefully enlarge the tubes.

► Building the fuselage

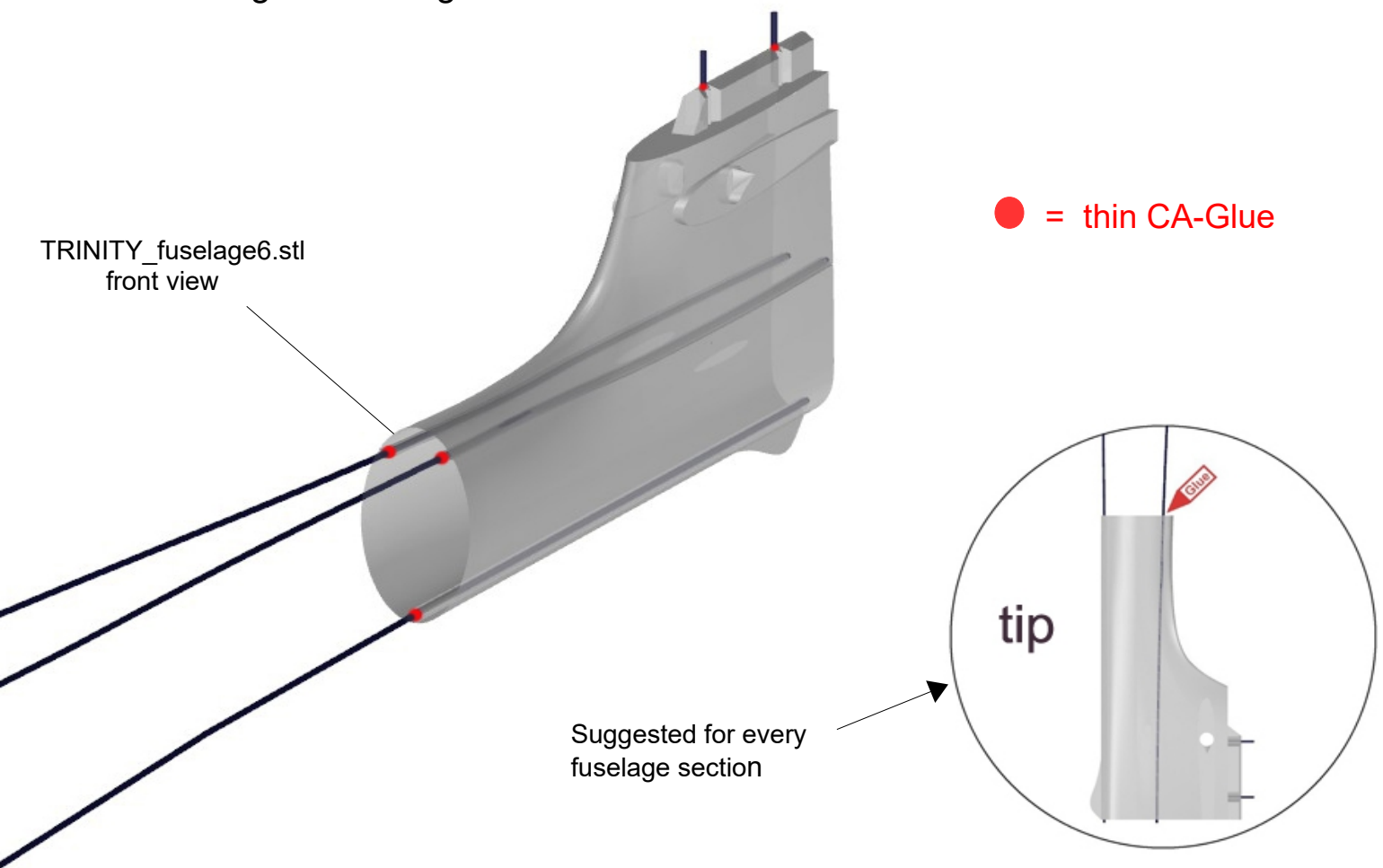

TRINITY_fuselage5.stl

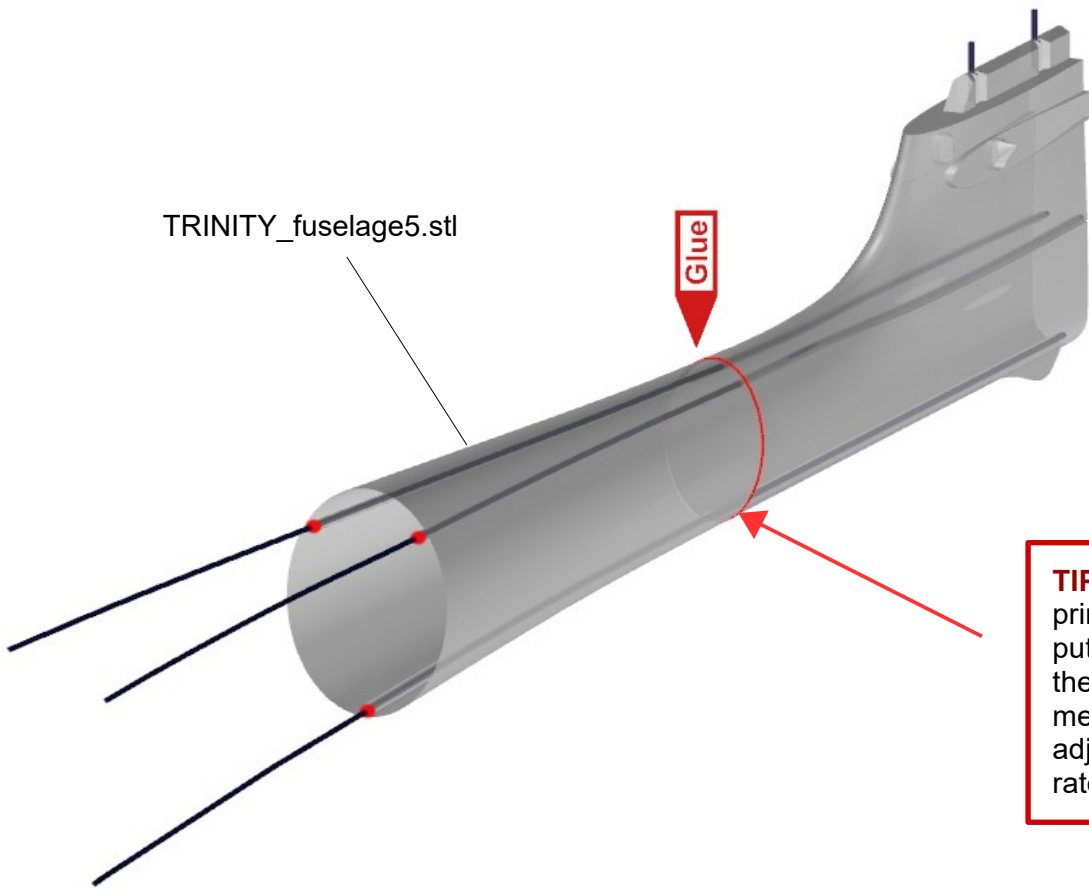

TIP: When assembling the printed parts, it is enough to put some **thin CA-Glue** on the outside of the fin. This means, you can step by step adjust the surfaces accurately while gluing

TRINITY_fuselage4.stl

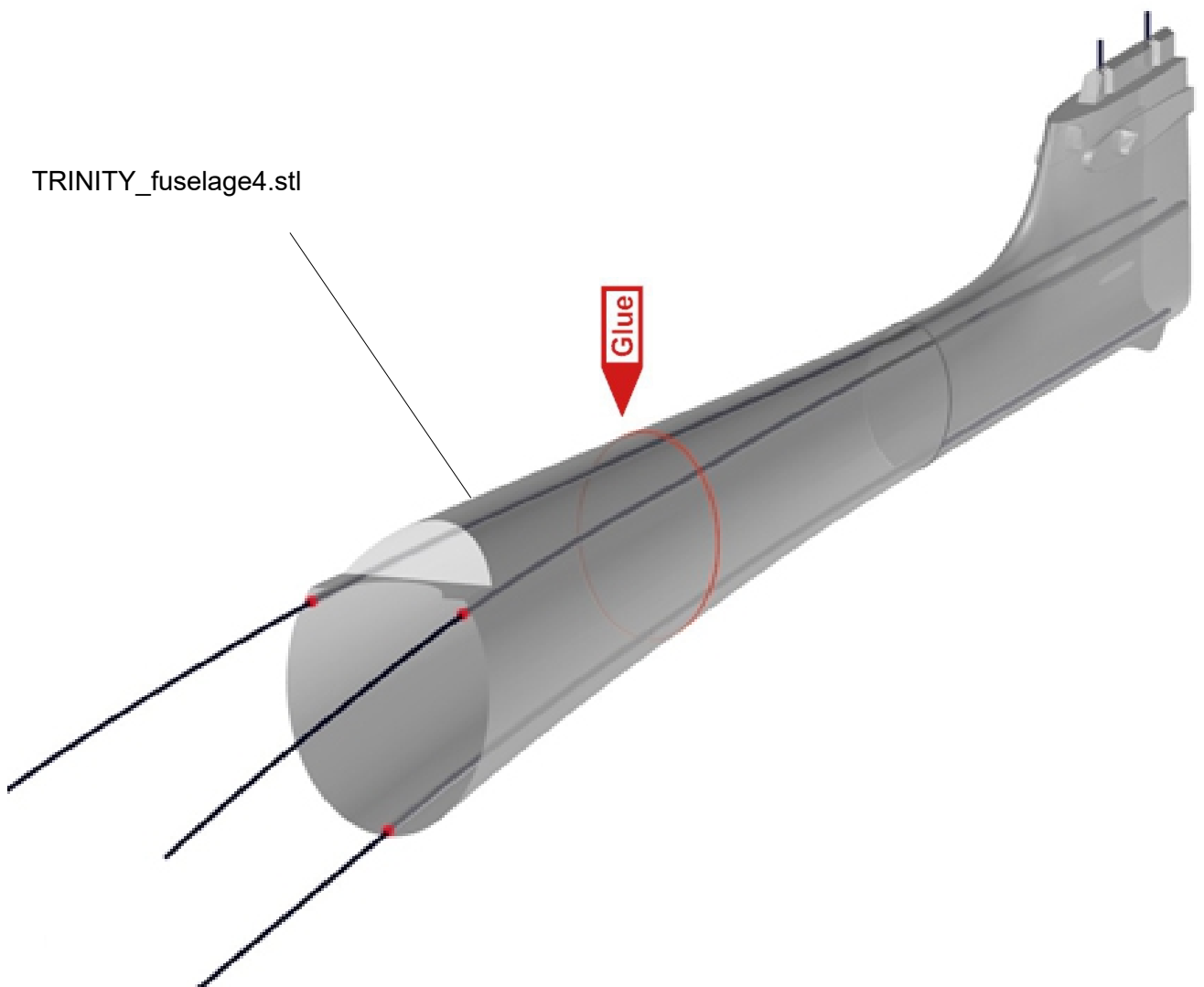

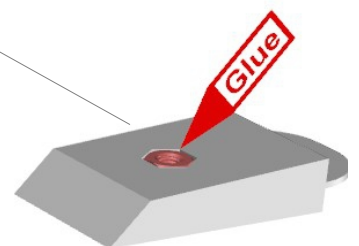
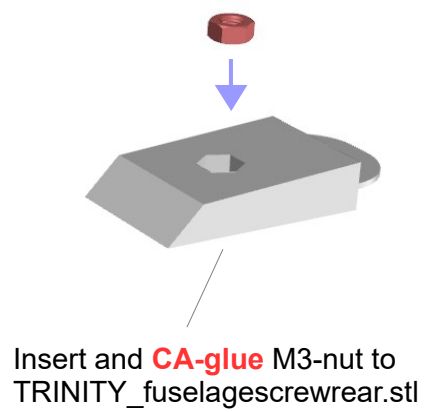
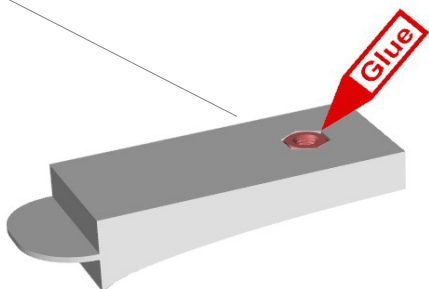
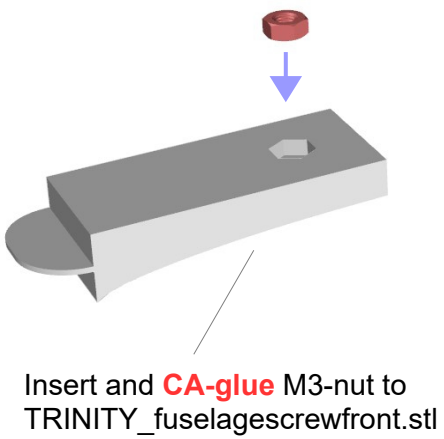
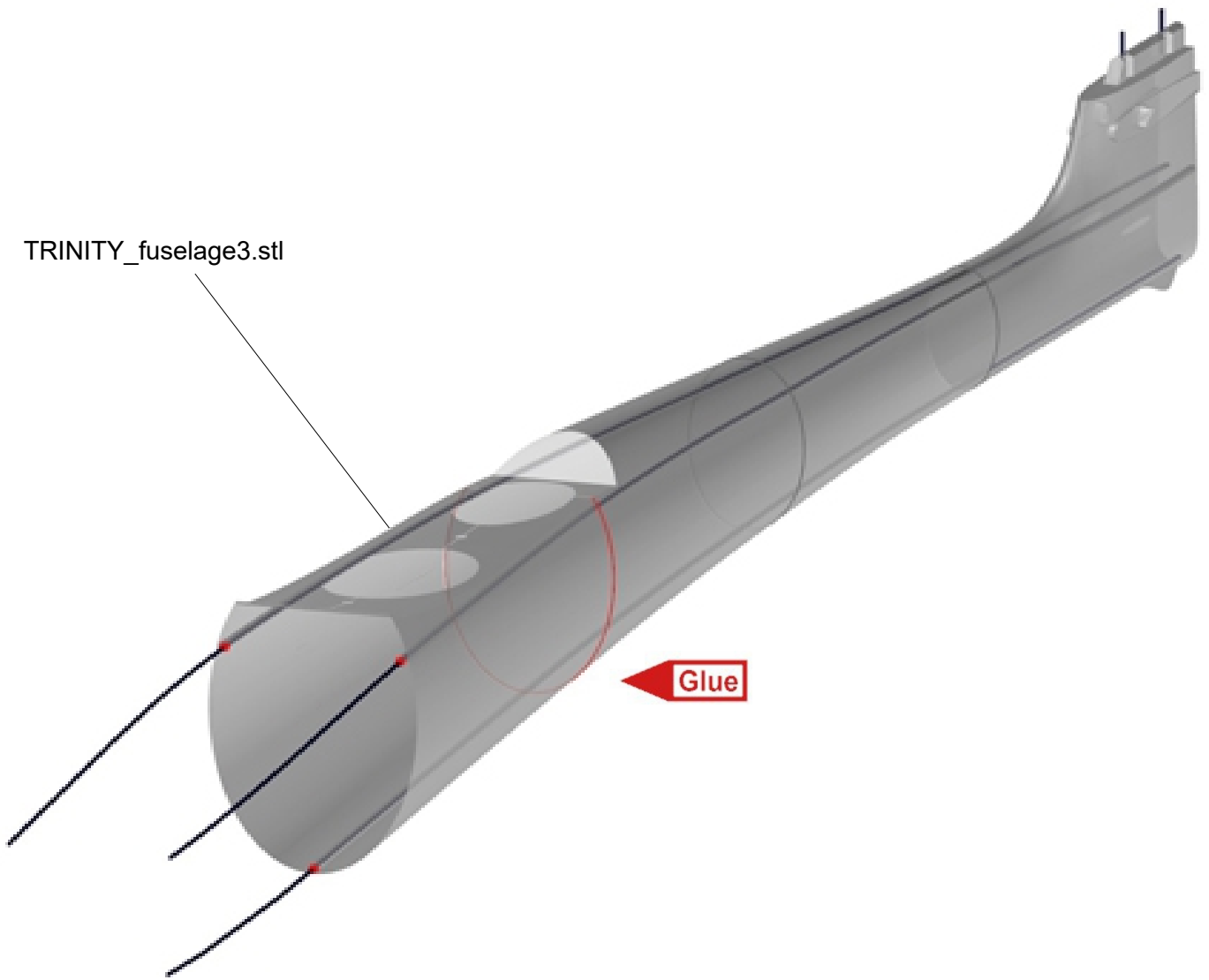

Assembling of fuselagescrews
Use **5-min-Epoxy** for gluing
(or medium CA)

M3x30 cylinder head screw
for fixing the wing

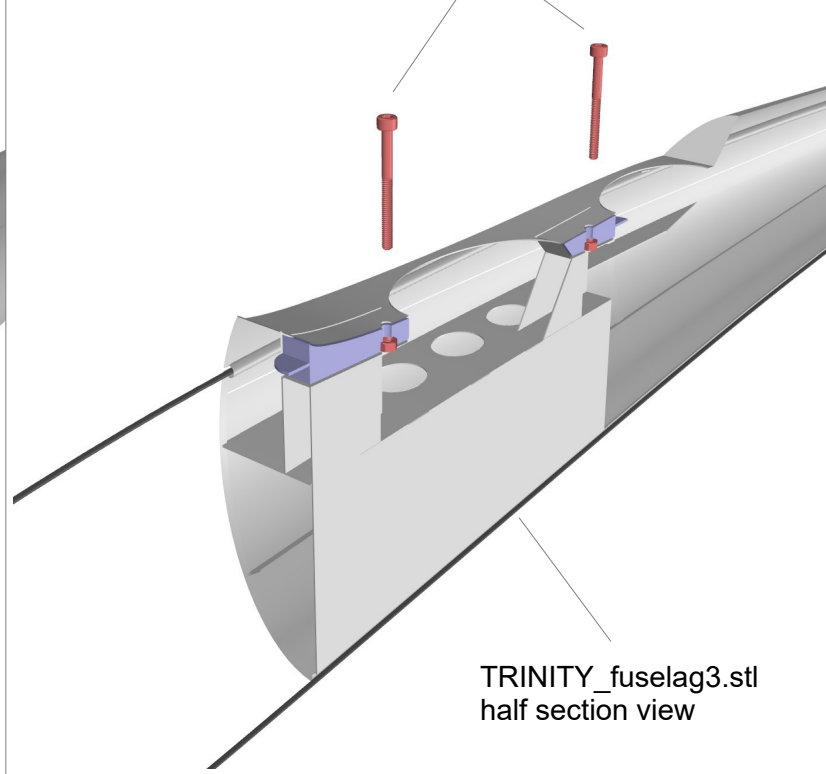
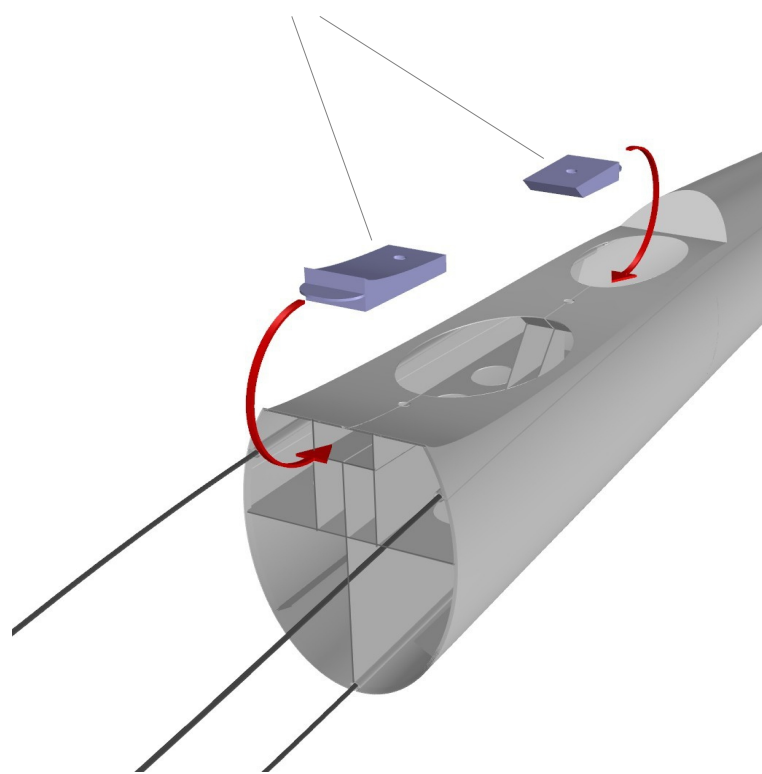

TRINITY_fuselage2.stl

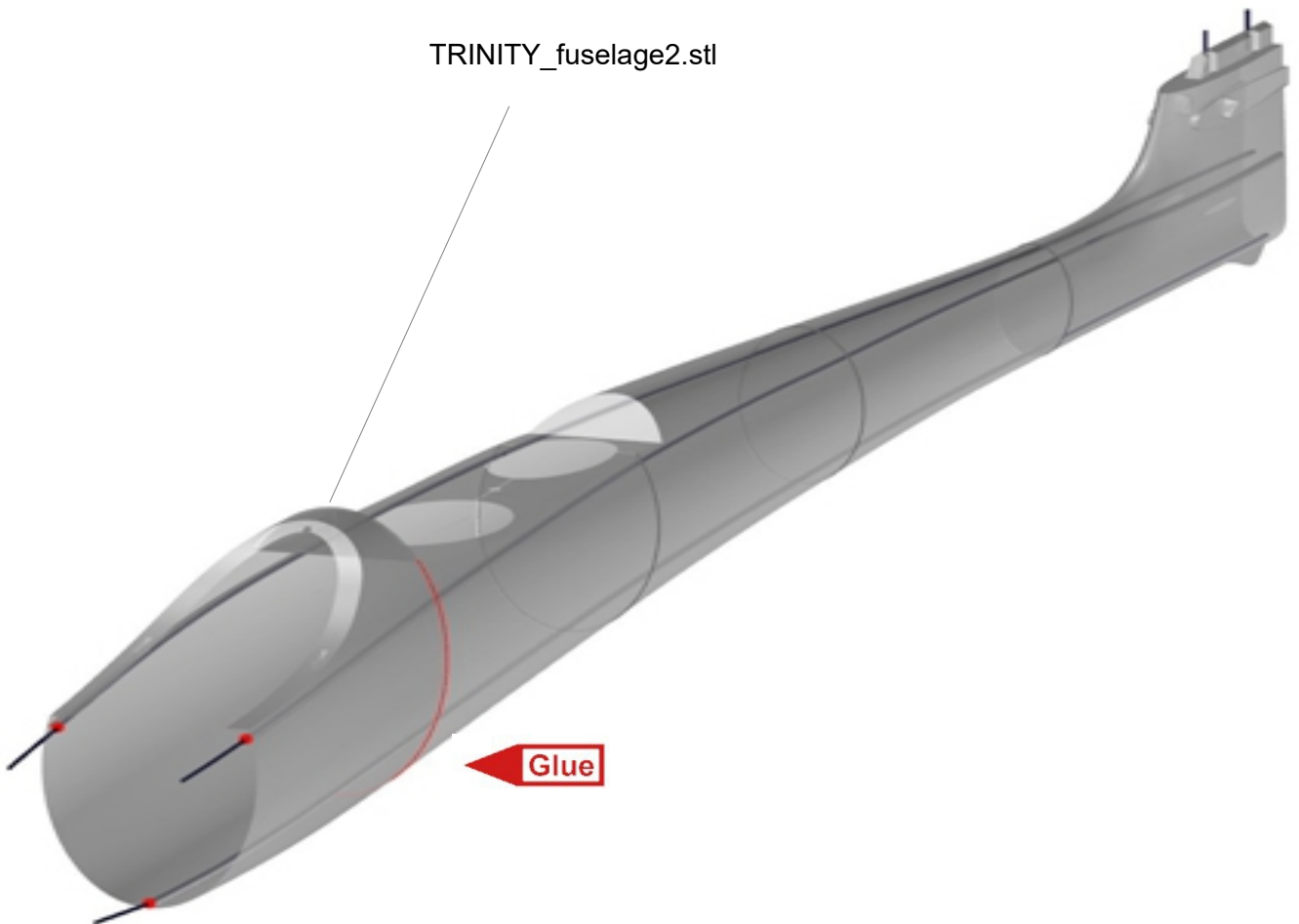

Ø1,5x1000mm cfk-rod - ca.
45mm overhanging front
of TRINITY_fuselage2.stl.

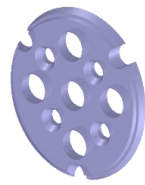
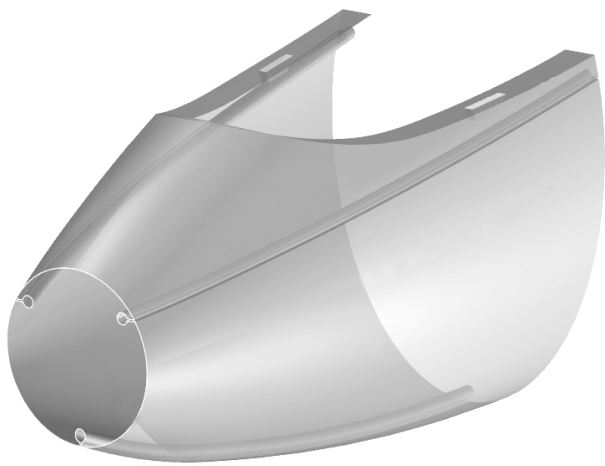
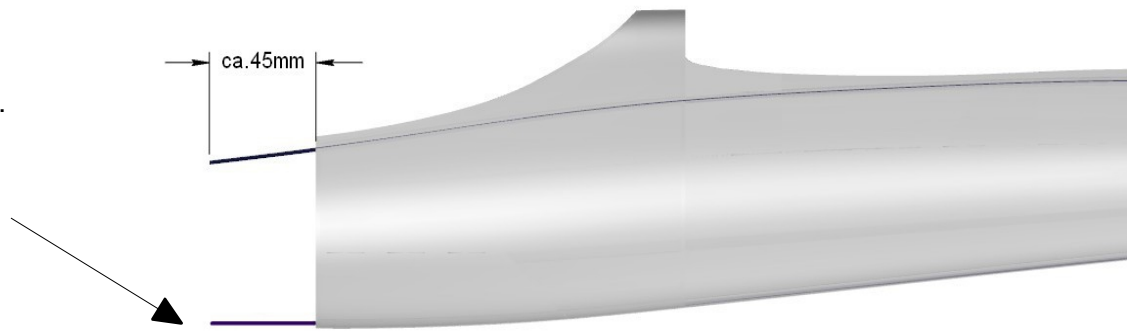

TRINITY_motormount.stl, two
versions with **16 /19 mm** screw
holes or without screw holes for
individual solution

TRINITY_fuselage1.stl

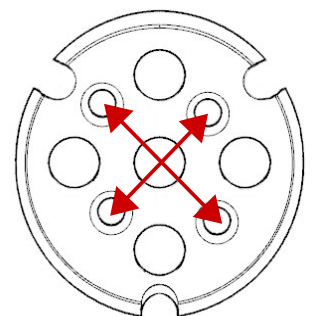
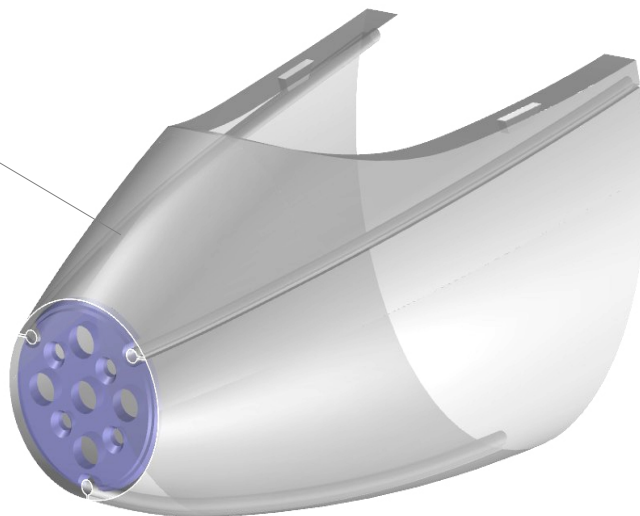

TRINITY_fuselage1.stl

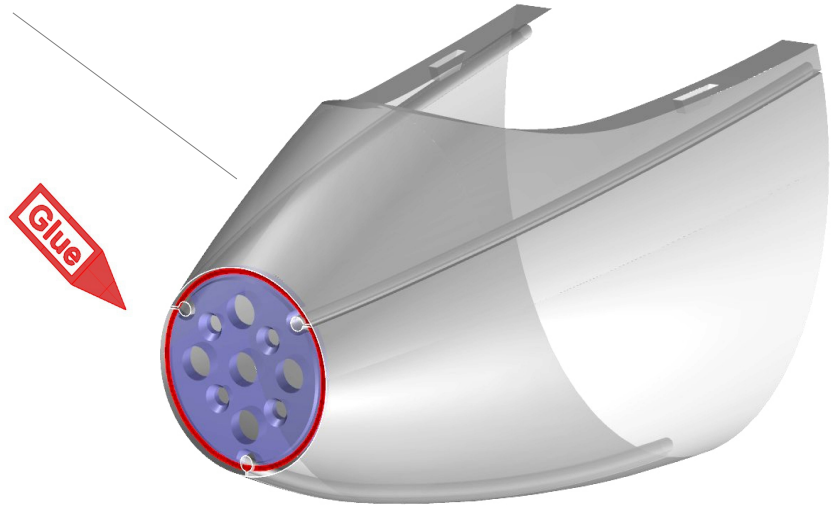

Make sure the motormount is
aligning to front of fuselage

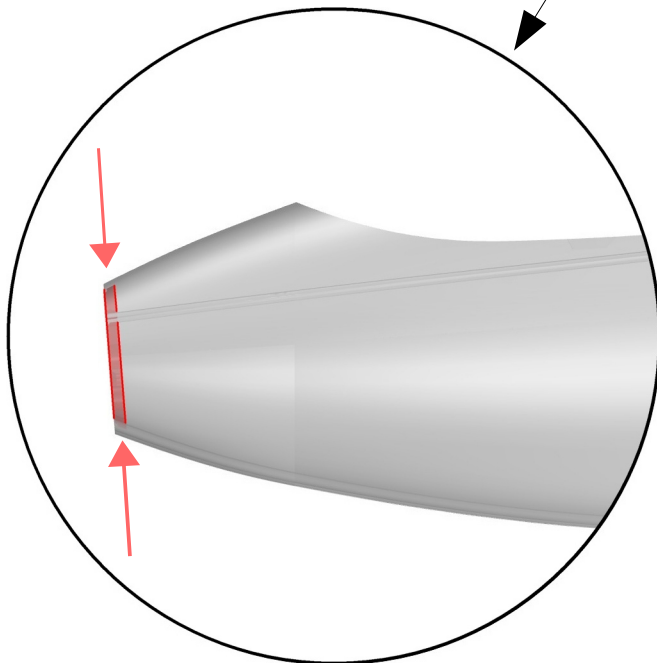

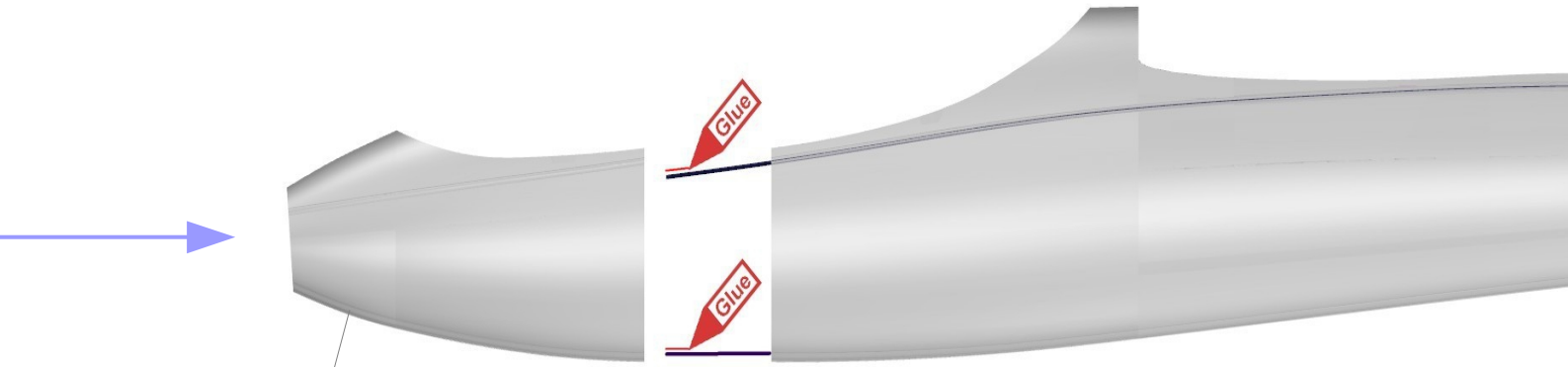

using medium-CA for gluing, you must be very quick inserting the Ø1,5mm-Cfk rods into the fuselage tubes !!

We use **5min-Epoxy** for gluing the rods in this case

TRINITY_fuselage1.stl

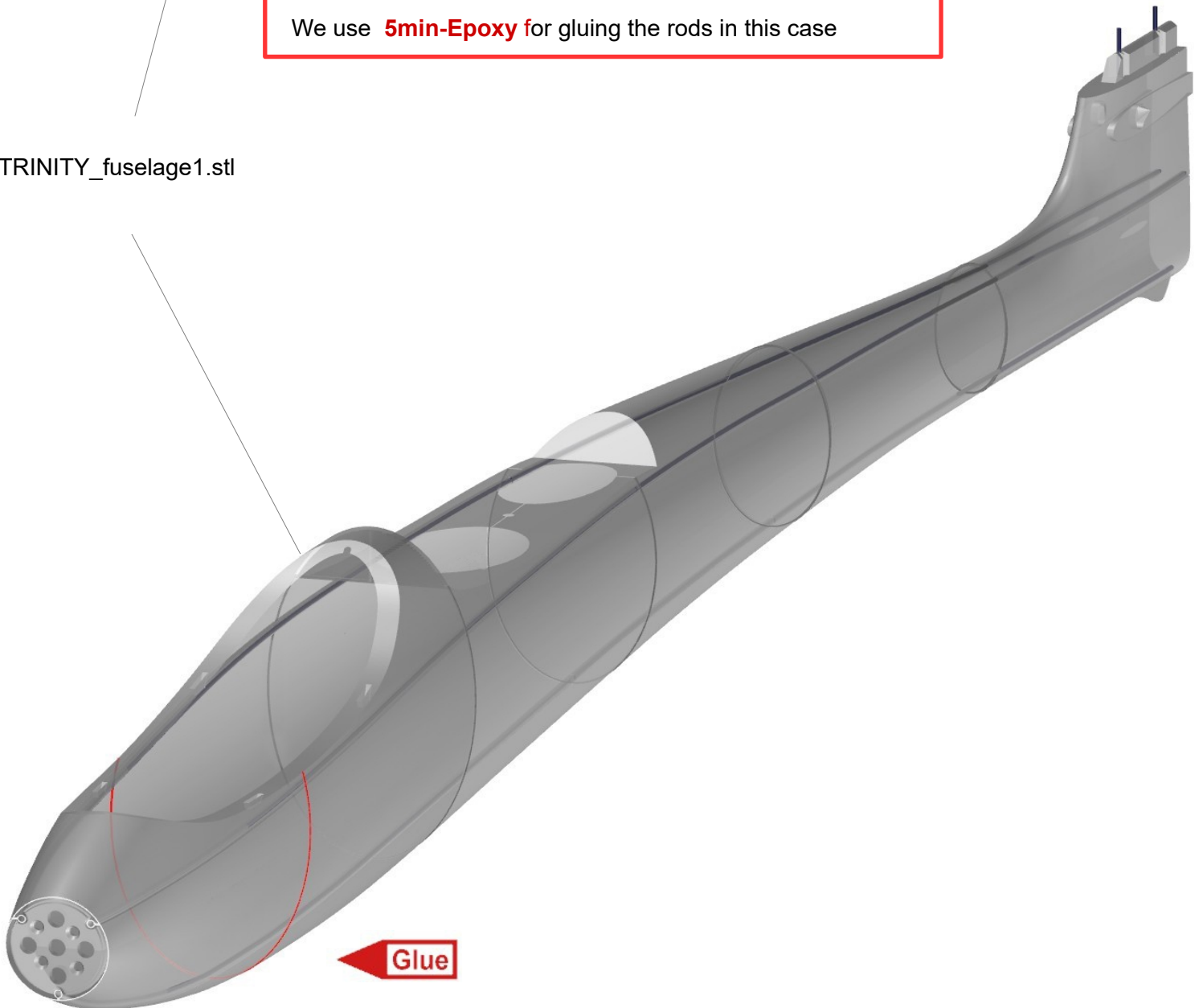

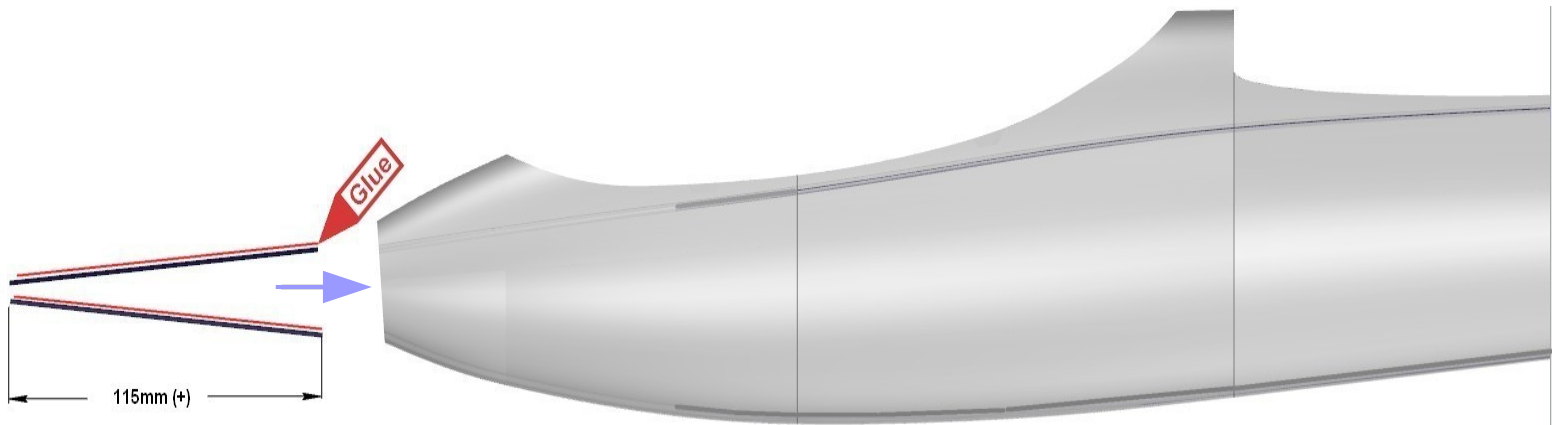

using medium-CA for gluing, you must be very quick inserting the $\varnothing 1,5 \times 115\text{mm}(+)$ Cfk rods into the fuselage fences !!

We suggest to use **5min-epoxy** for gluing and to keep the rods longer. Cut overhanging after gluing - except glider version, see page 37.

3 x $\varnothing 1,5 \times 115\text{mm}$ Cfk-rods

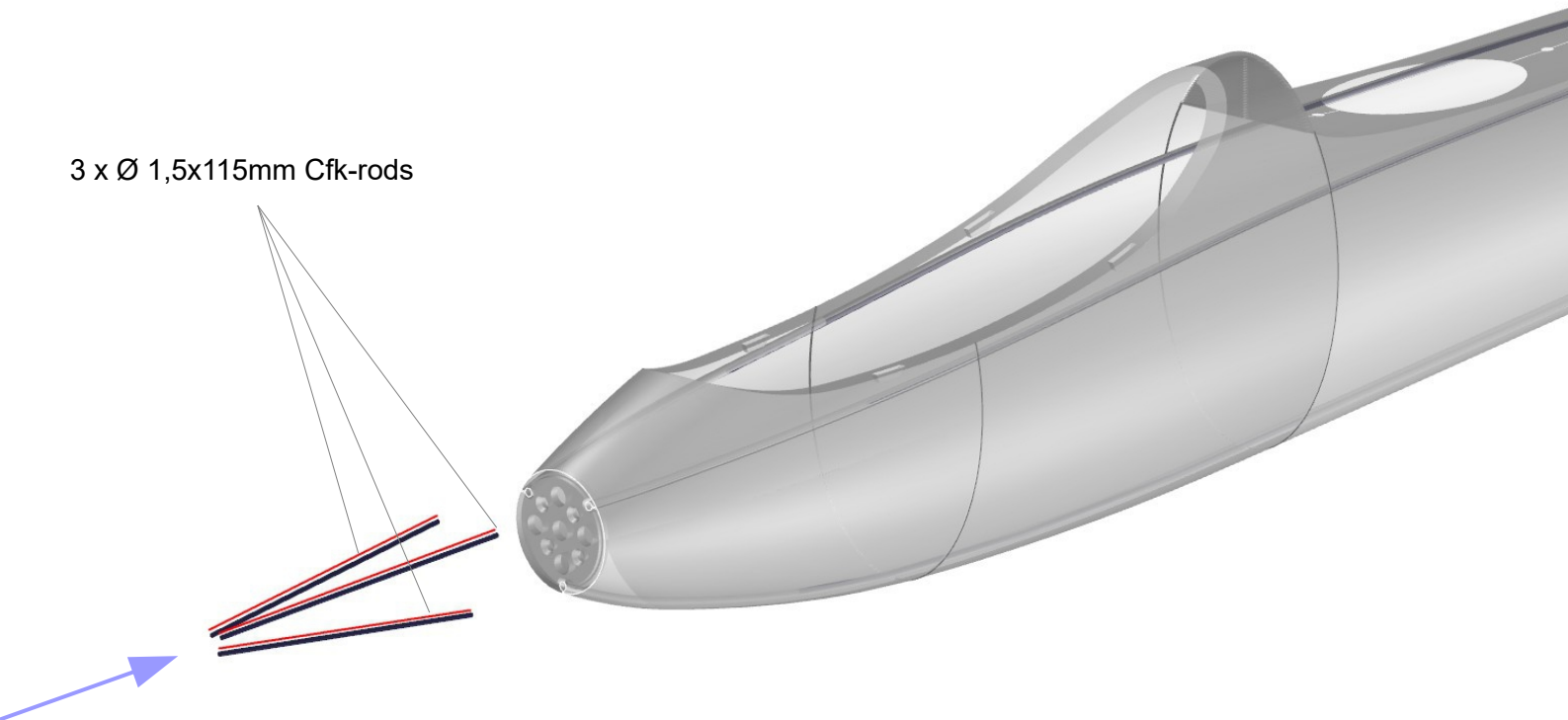

TRINITY_canopyrear.stl

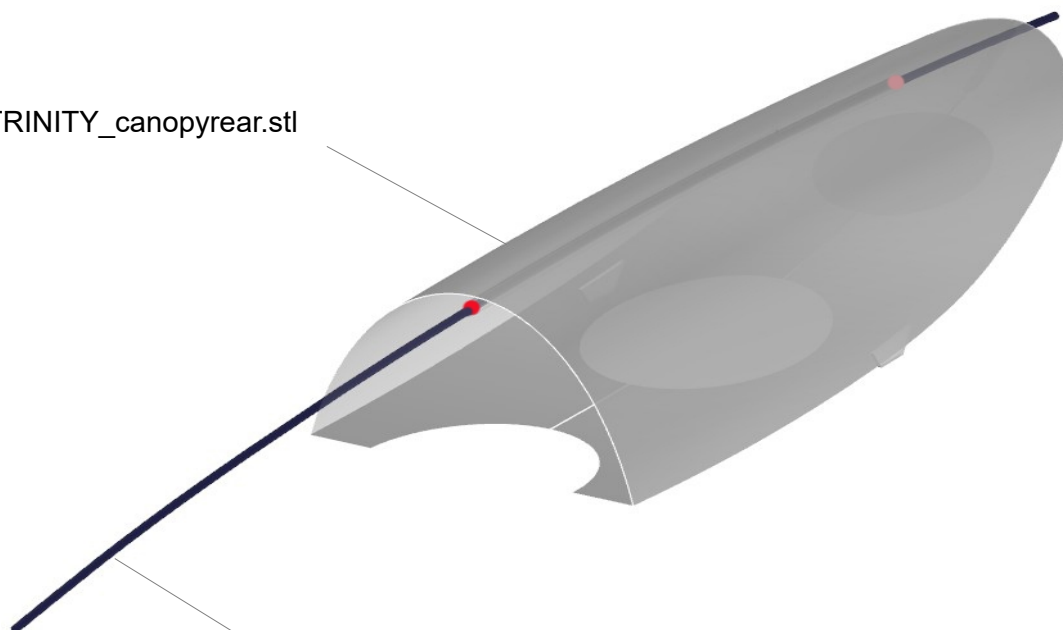

Ø1,5x260mm cfk-rod

TRINITY_canopyfront.stl

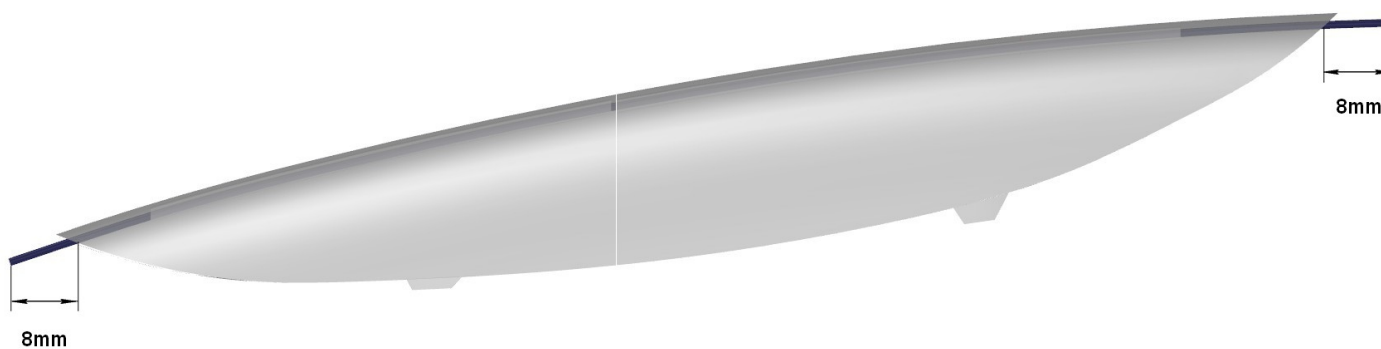
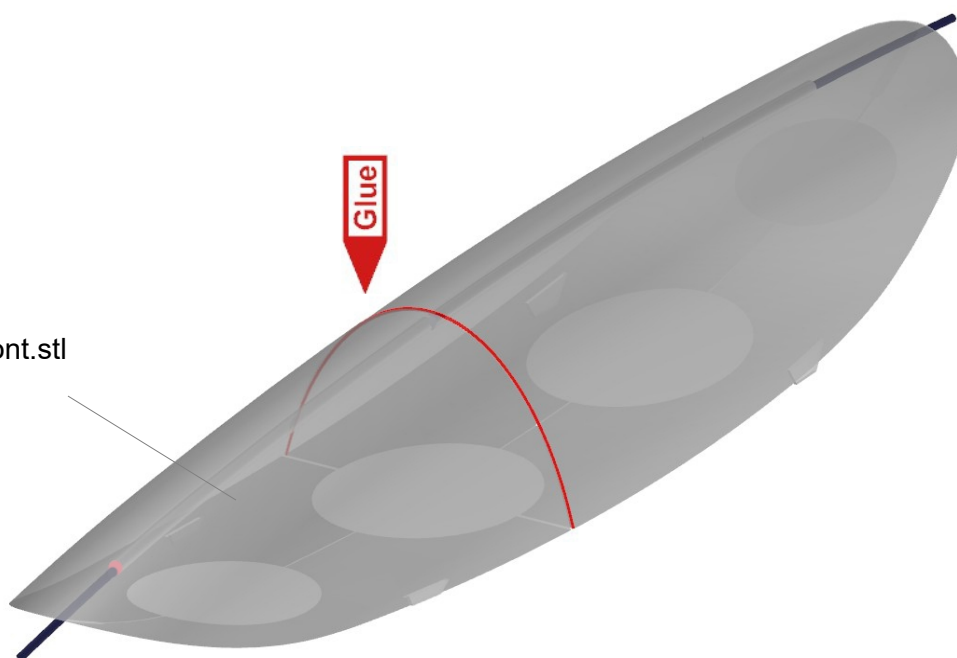

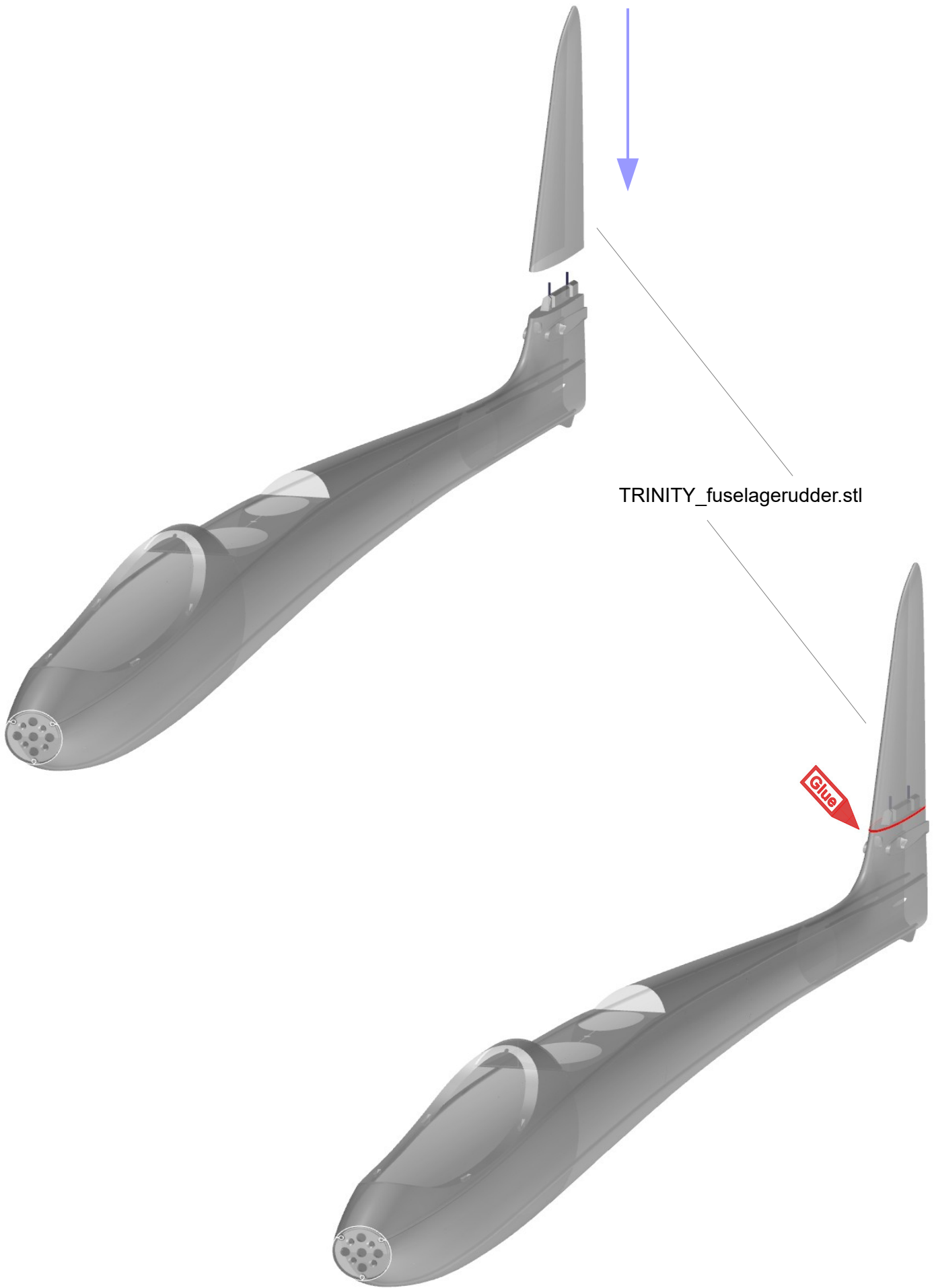

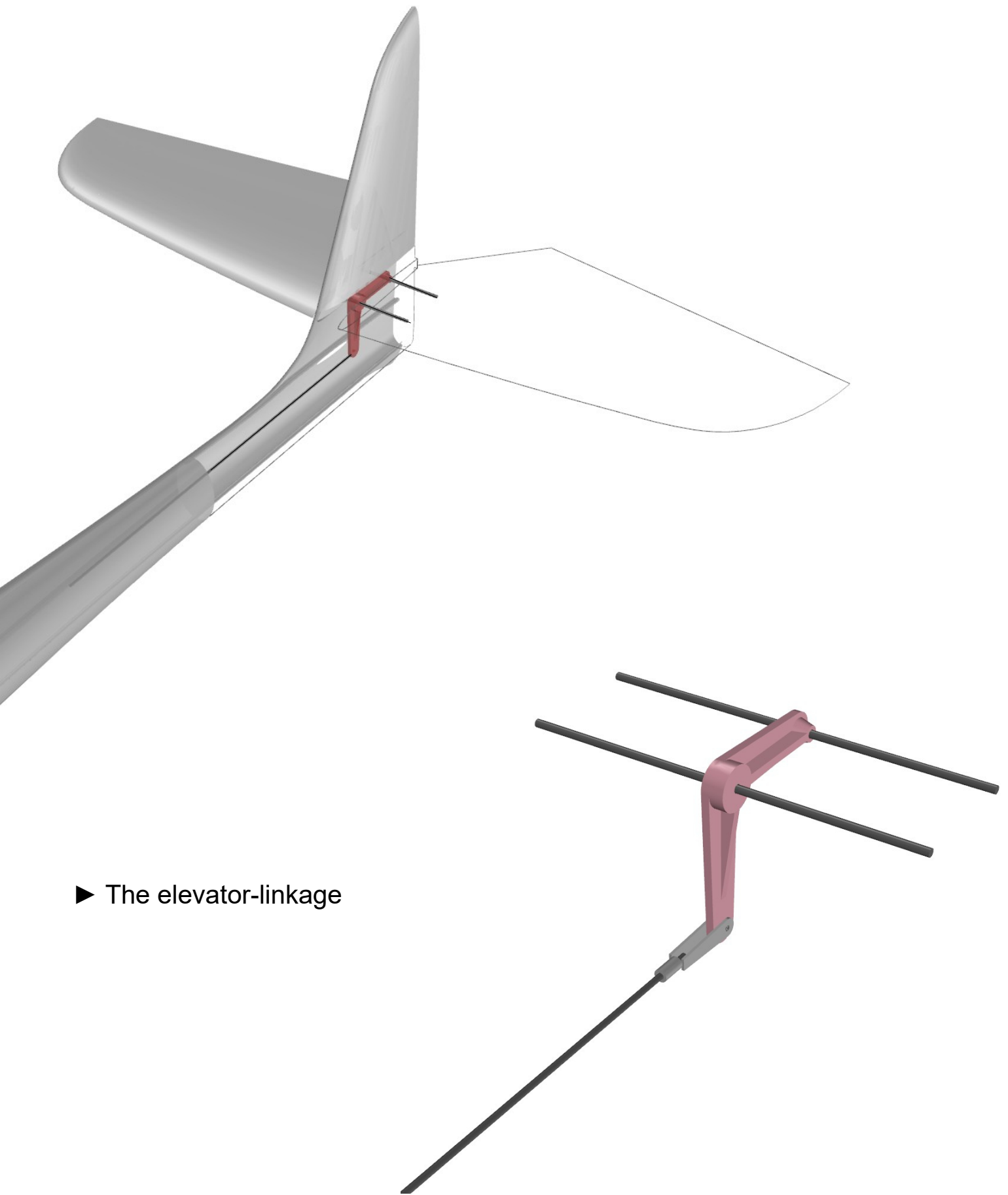

► The elevator-linkage

► Building the linkage

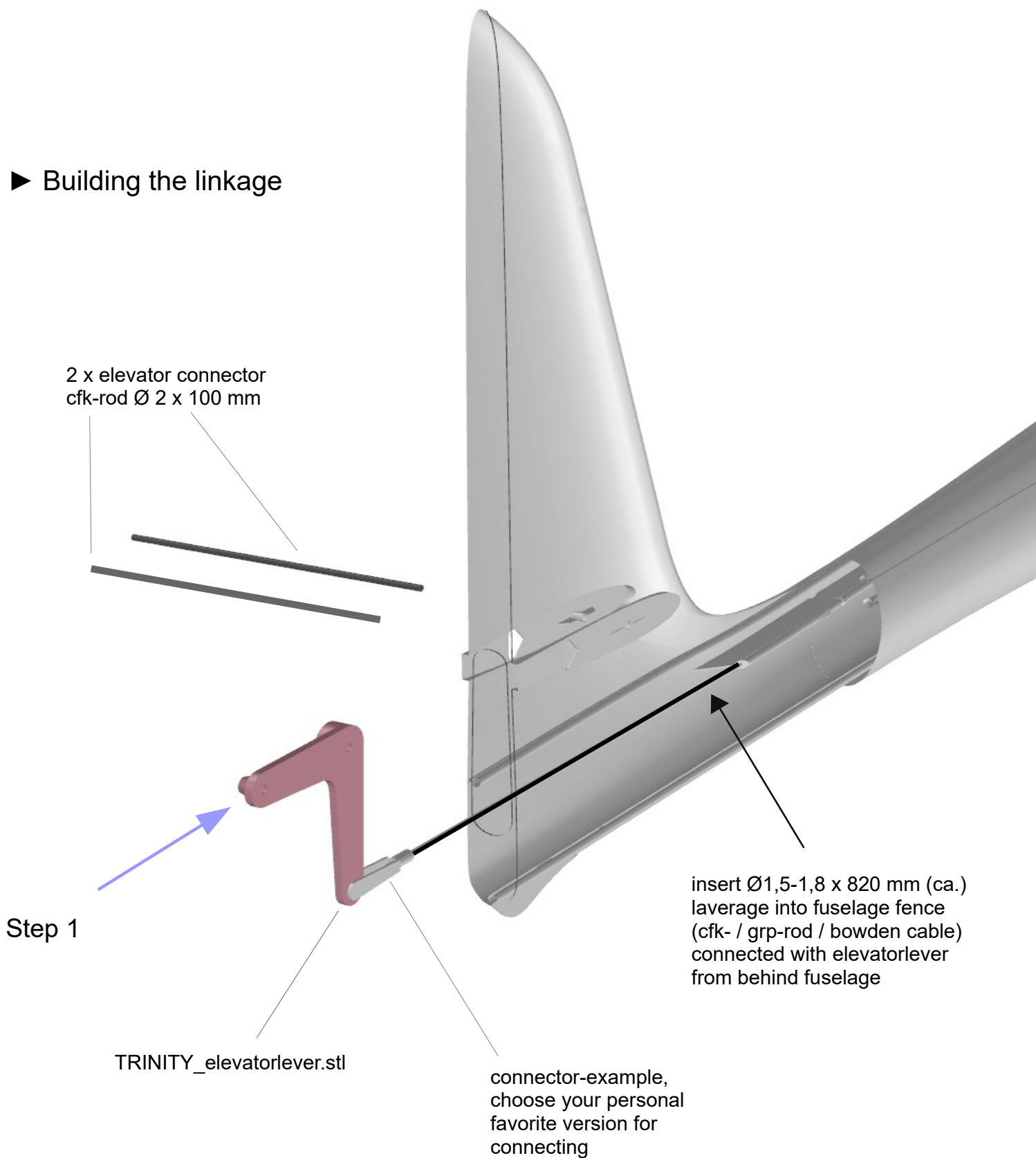

Step 2

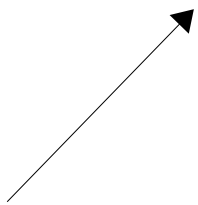
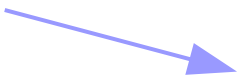

insert connector to fuselage and
elevator lever without gluing

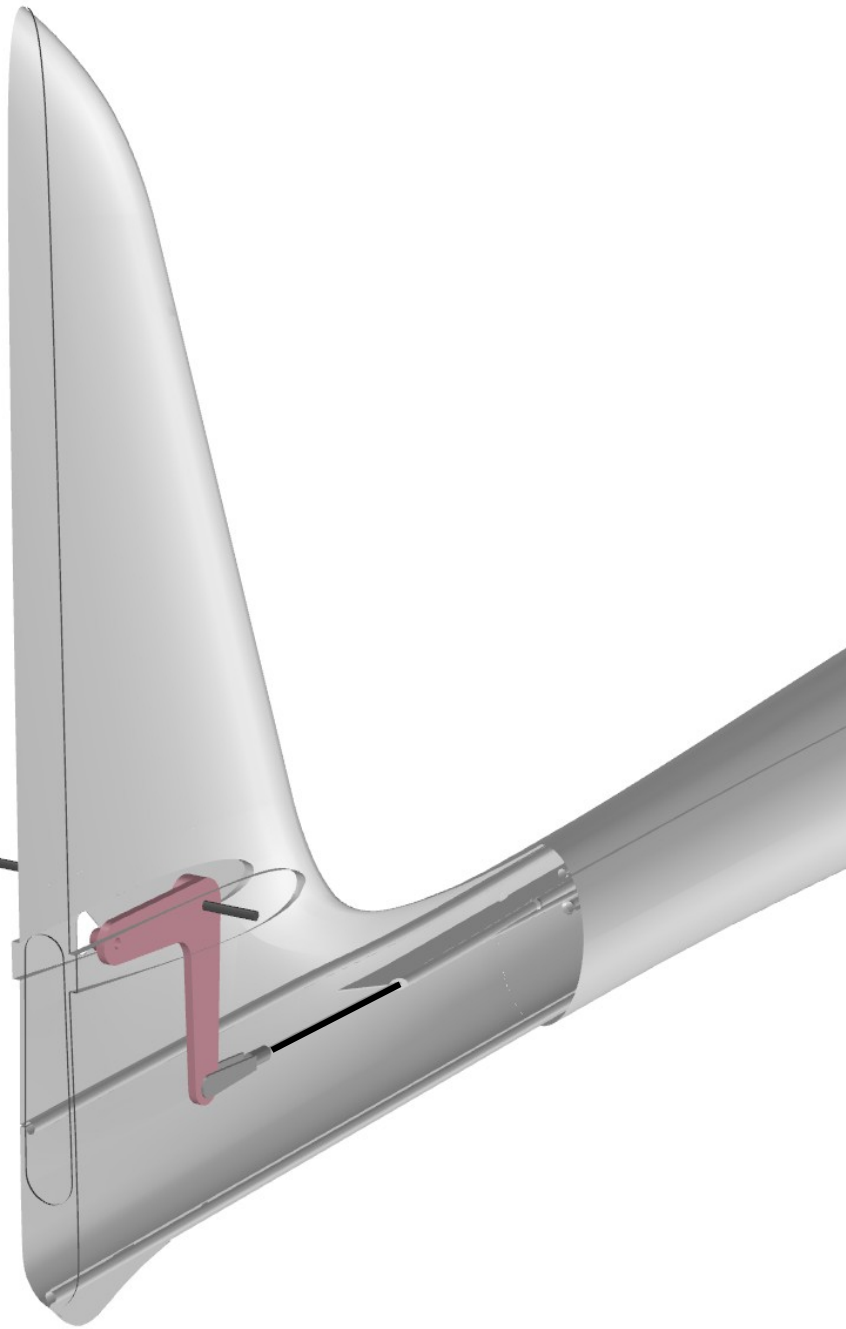

► Building the rudder

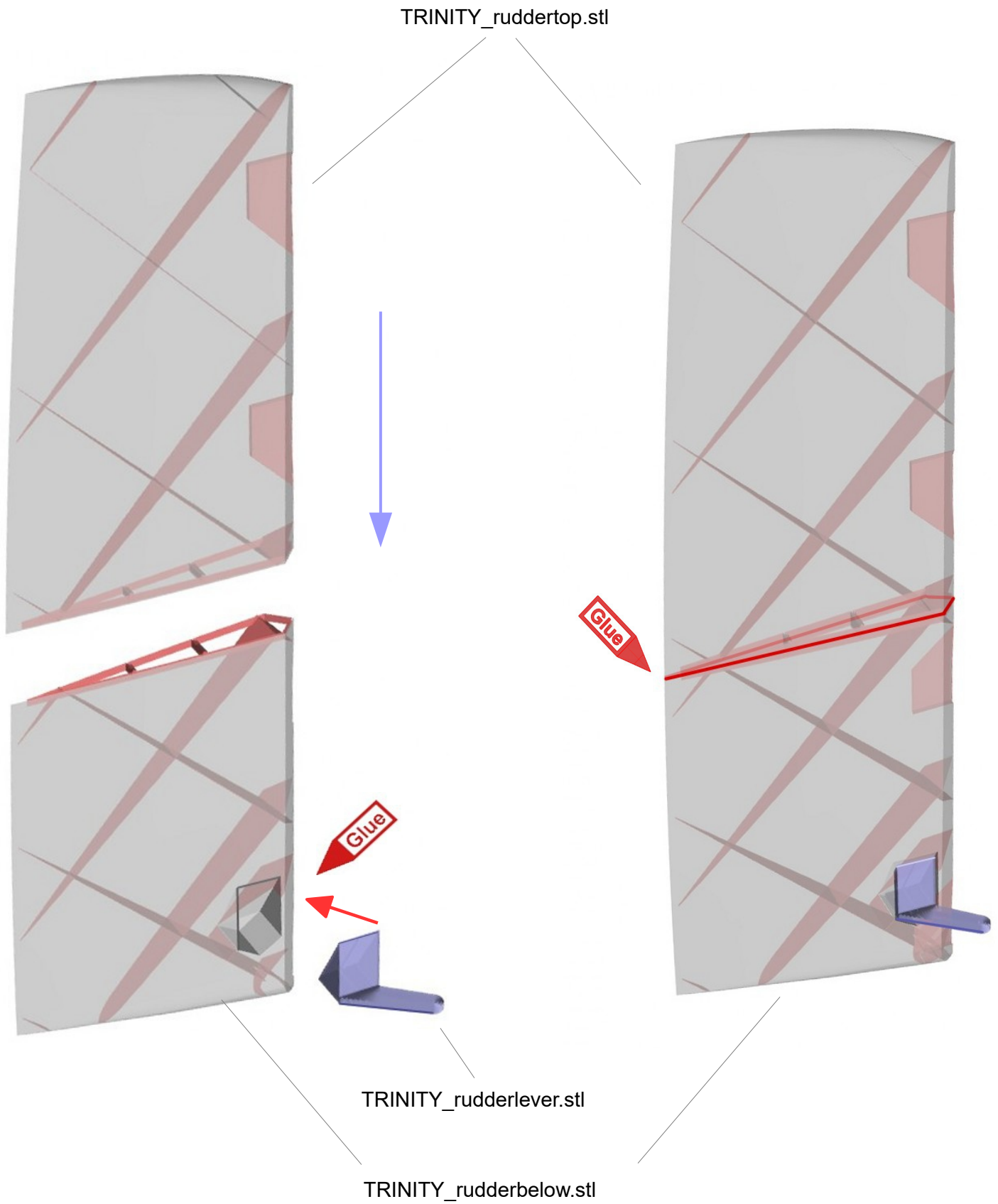

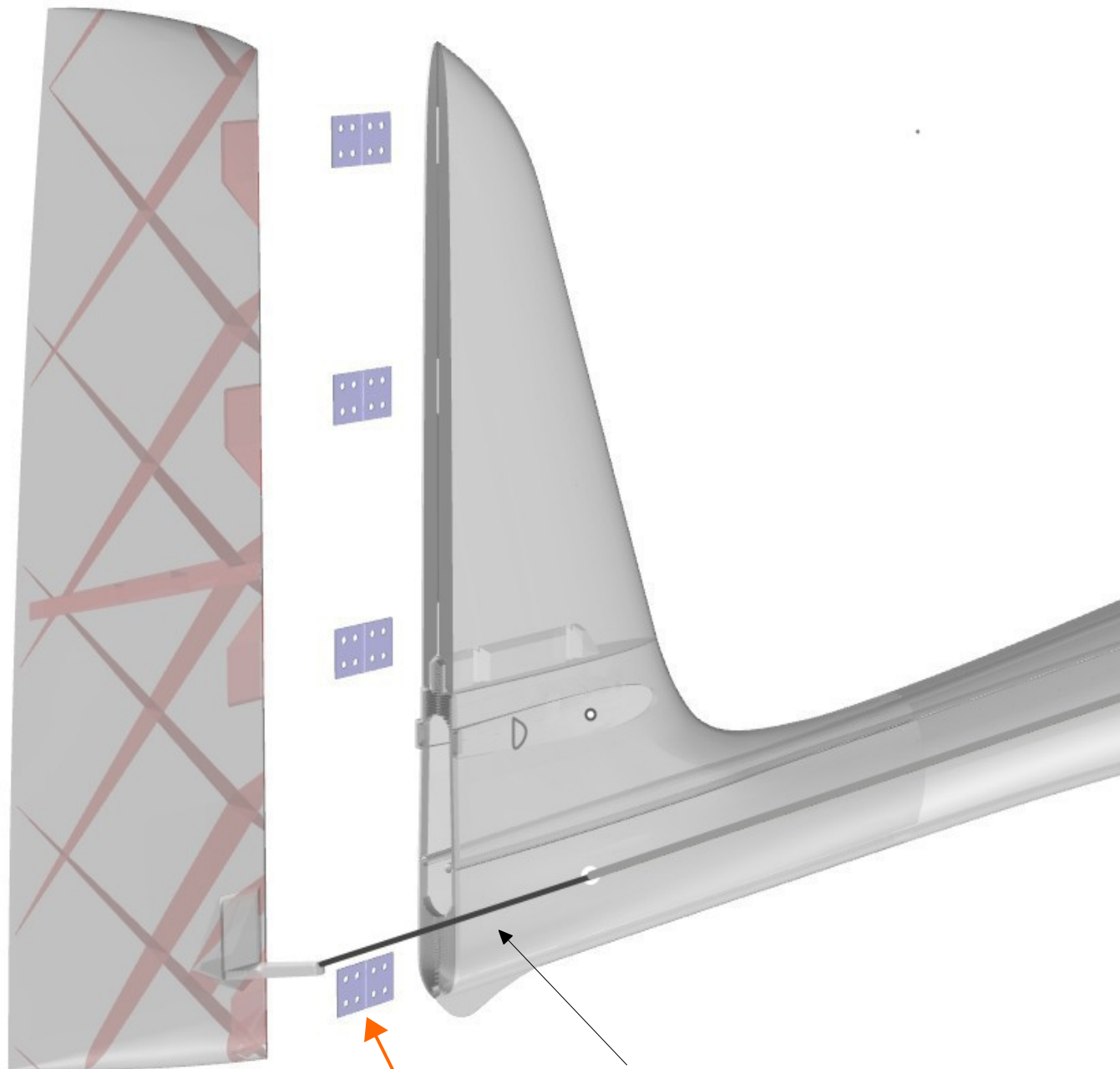

insert $\varnothing 1,5-1,8$ x 850 mm (ca.)
laverage into fuselage fence
(cfk- / grp-rod / bowden cable)

glue 4 film hinges, 22x12x0,6mm

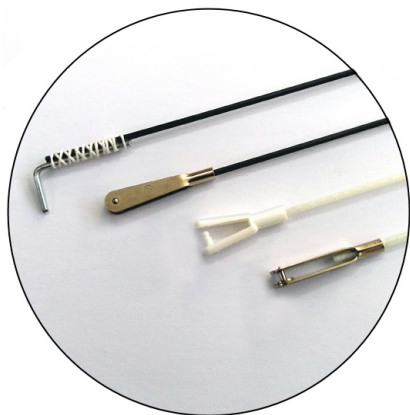

Various rudderlever connectors
can be used

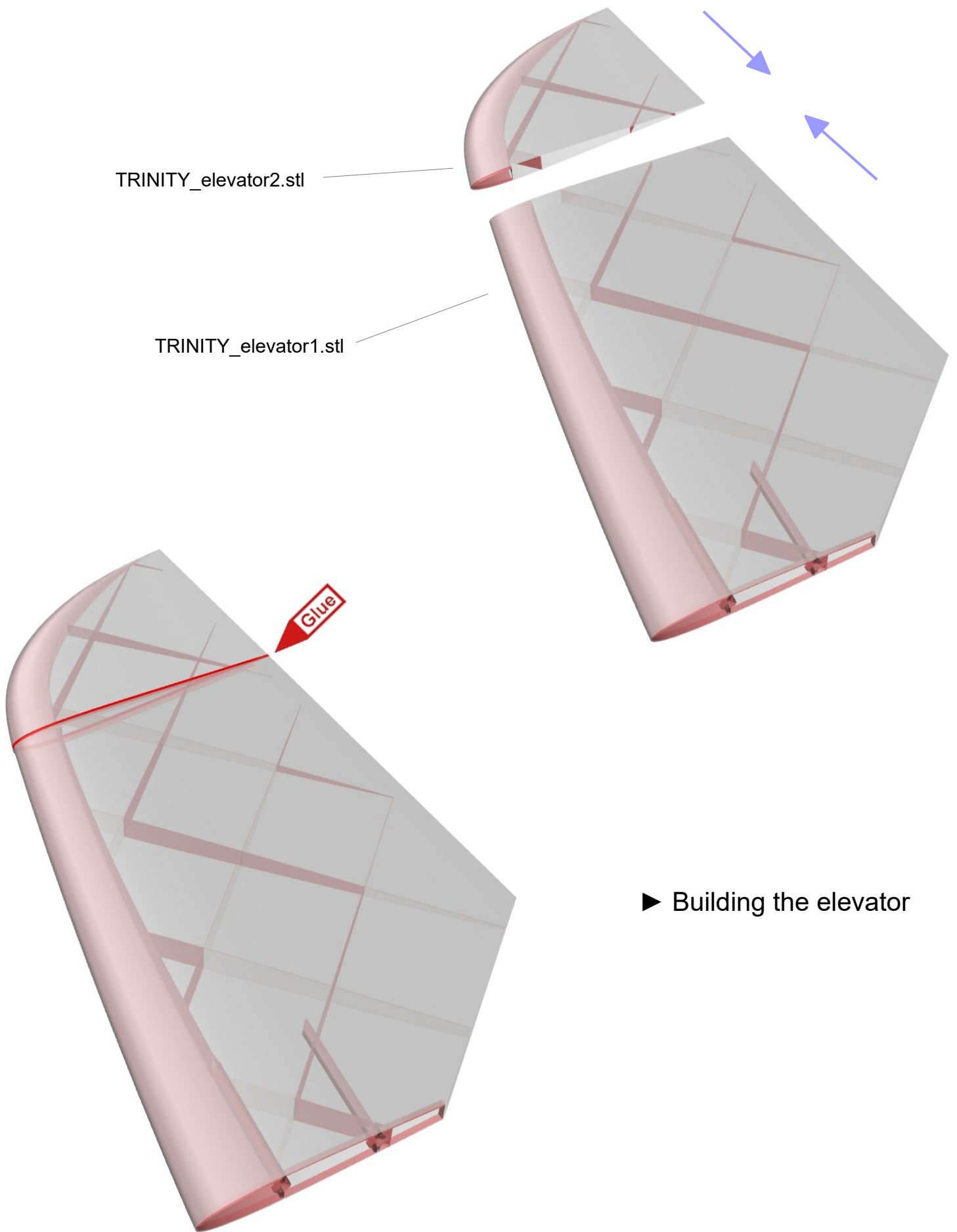

► Building the wing

NOTICE: YOU MUST NOT GLUE THE CARBON TUBE

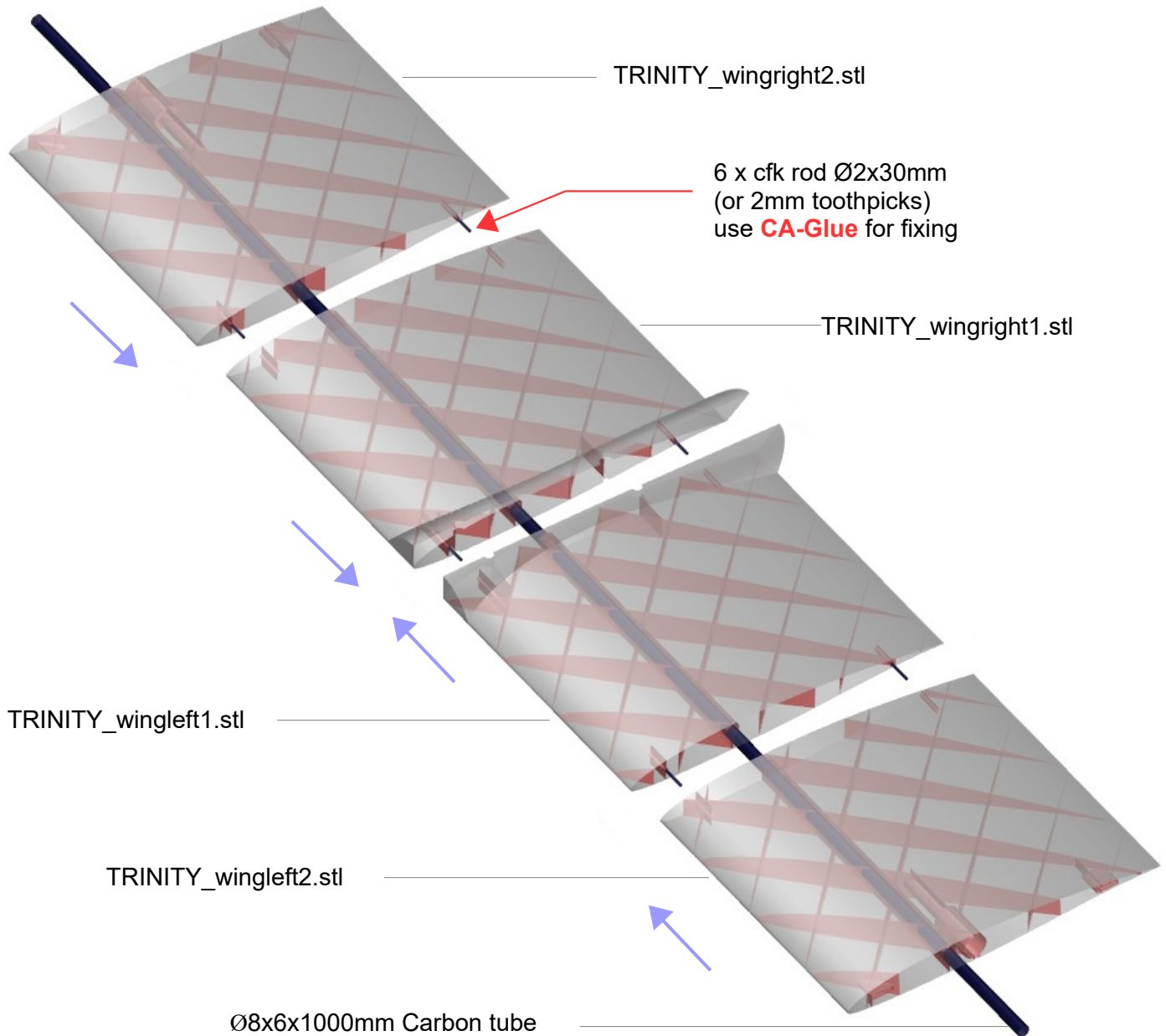

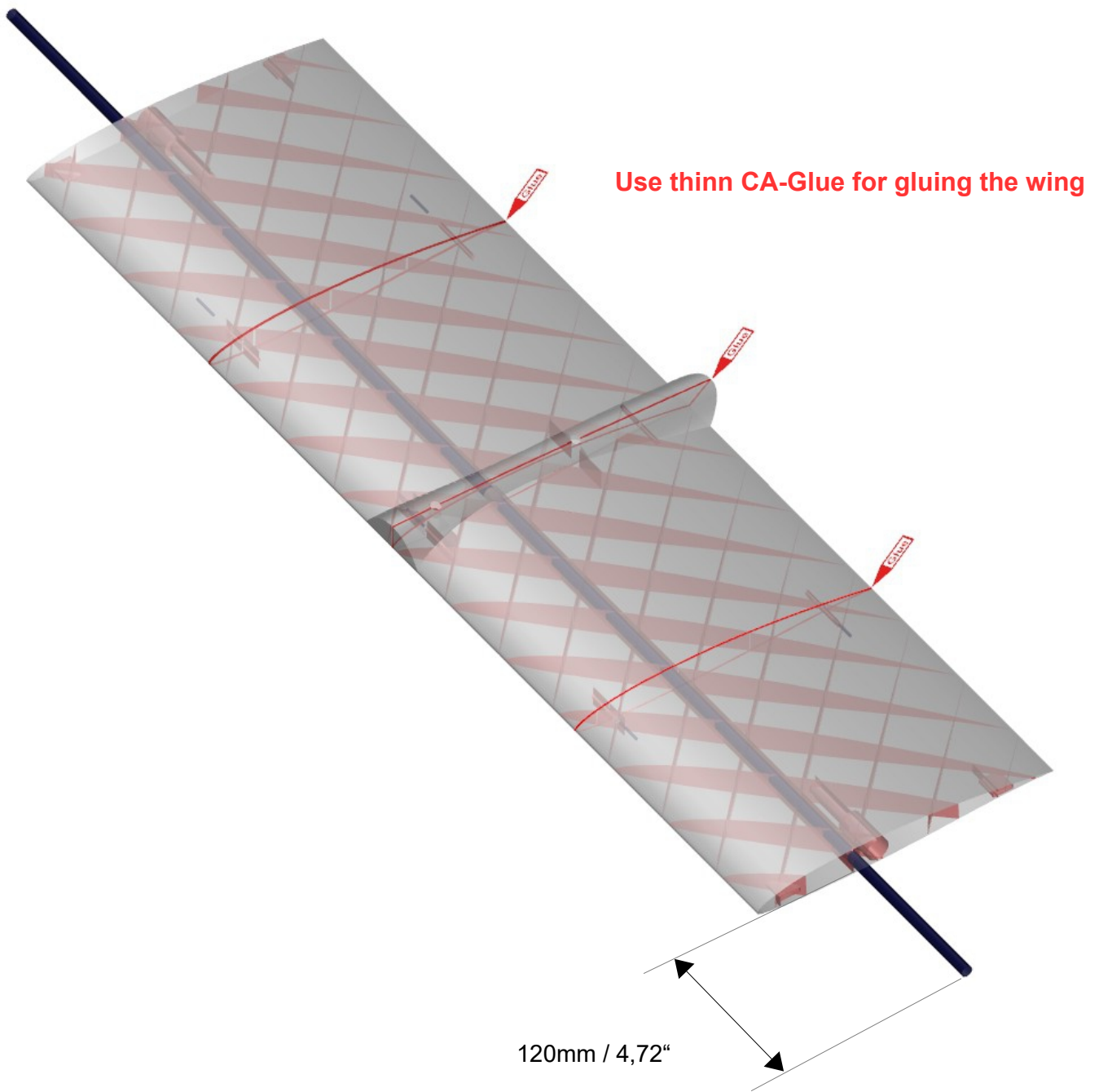

TIP: When assembling the wingparts, it is adequate to put some **thin CA-Glue** on the upperside and the bottom side of the fin. This means, you can step by step adjust the surfaces accurately while gluing.

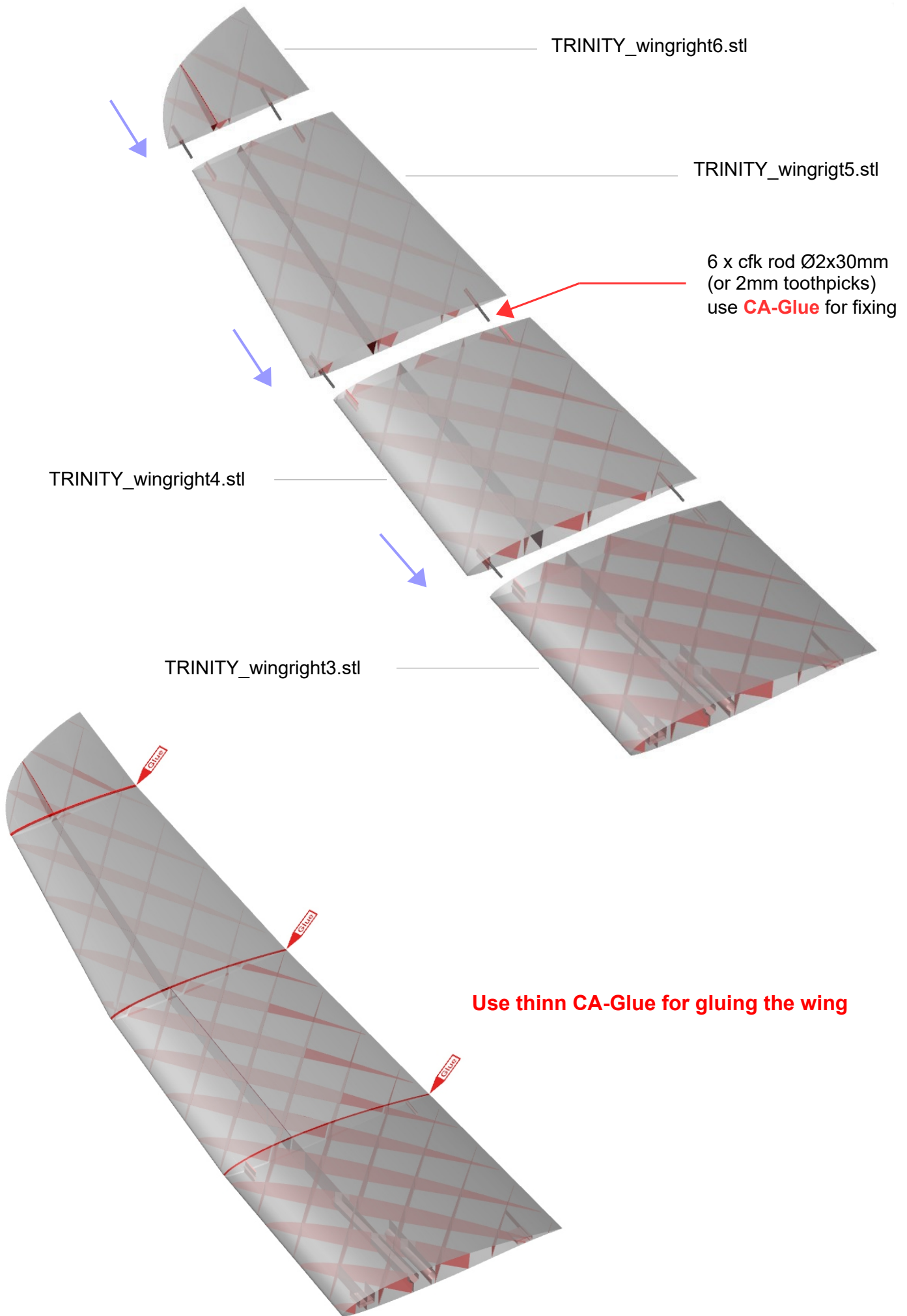

► Building the Wing Lock

toolless fitting between inner wing and side wings by snap lock ball combined with 2 wingpins on each wingside

Step 1: CA-glue a Ø2x17mm cfk-rod (or 2mm toothpick) in one side of ball fitting

Step 2: put CA-medium to ball-fitting as illustrated below and use snap lock ball to adjust other side of ball-fitting while assembling both parts.

Take care **NOT** to glue snap lock ball!

Step 3: remove snap lock ball.

Step 1

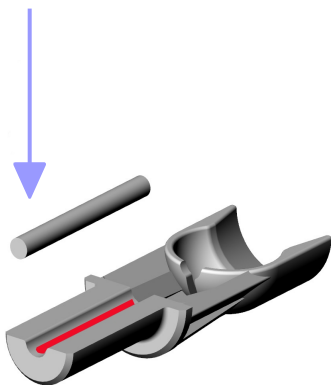

Step 2

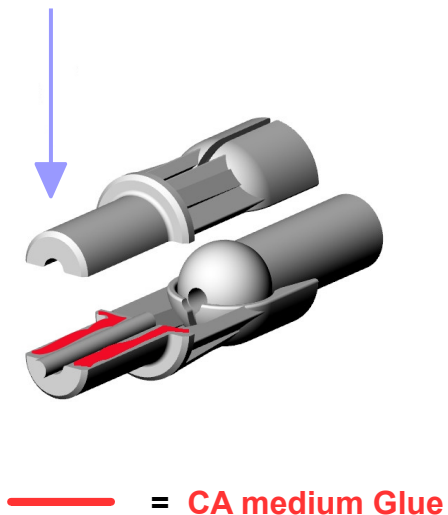

Step 3

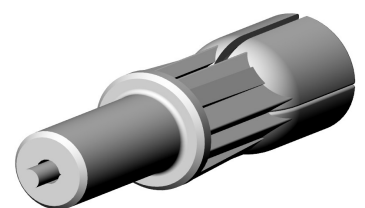

► Connecting the Winglock to the wing

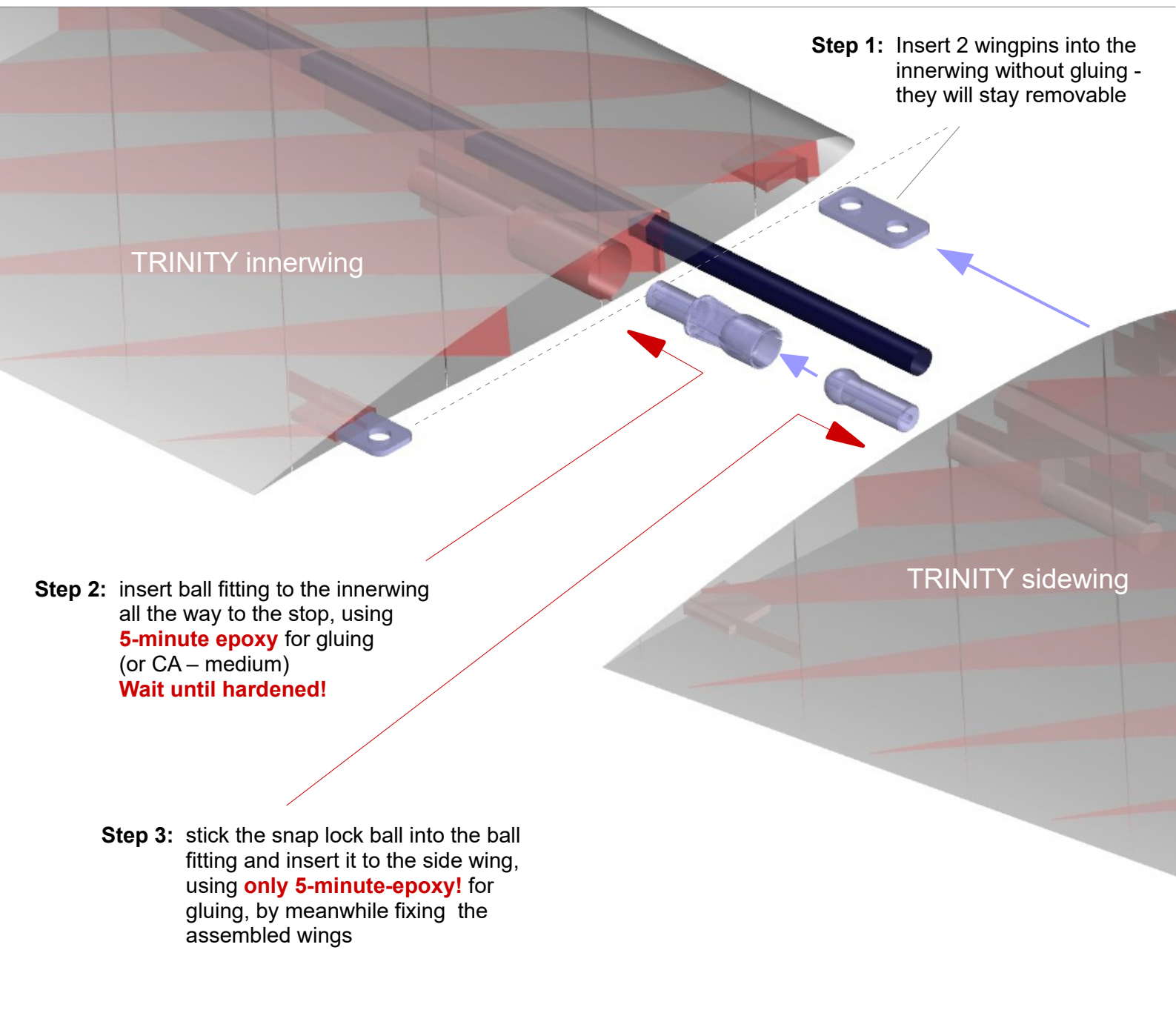

Step 1: Insert 2 wingpins into the innerwing without gluing - they will stay removable

Step 2: insert ball fitting to the innerwing all the way to the stop, using **5-minute epoxy** for gluing (or CA – medium)
Wait until hardened!

Step 3: stick the snap lock ball into the ball fitting and insert it to the side wing, using **only 5-minute-epoxy!** for gluing, by meanwhile fixing the assembled wings

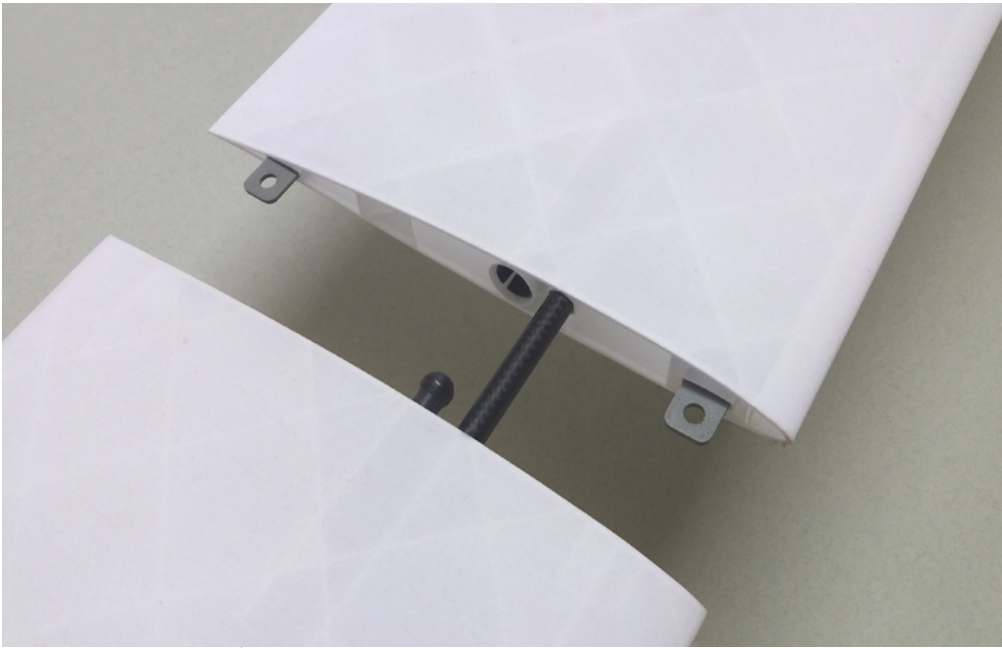

TRINITY sidewing



► Final Assembling of *TRINITY*

TRINITY_servomount.stl

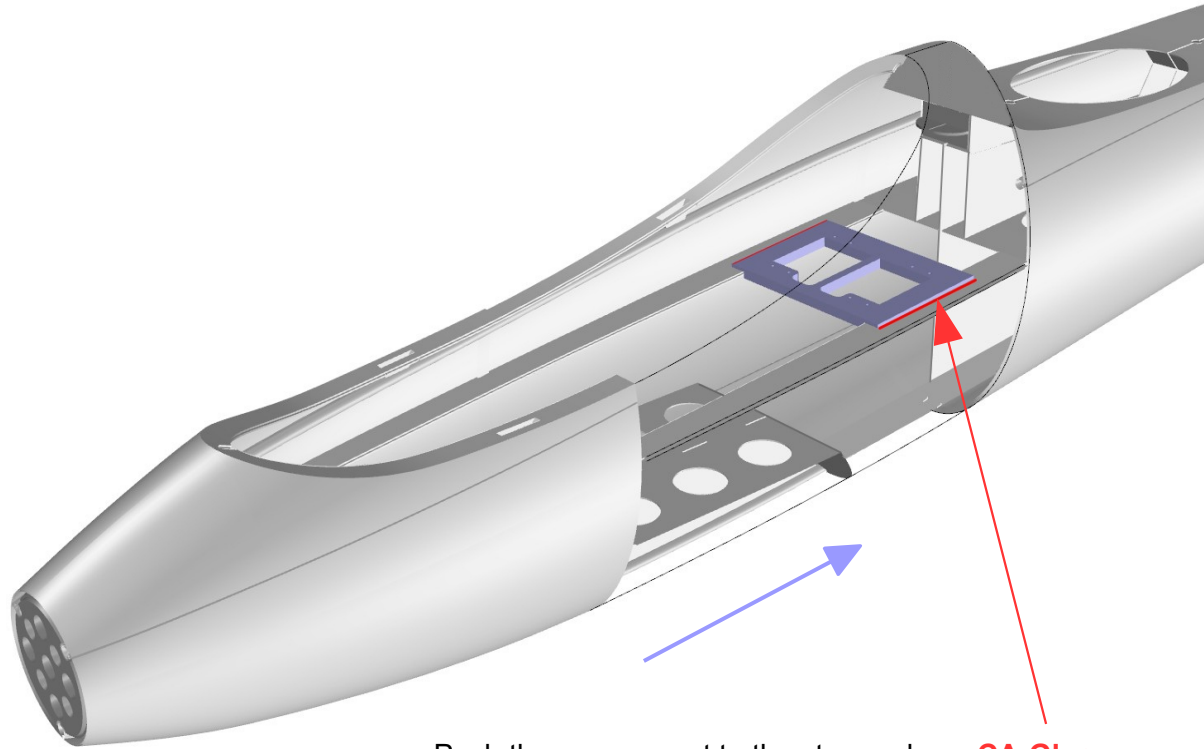
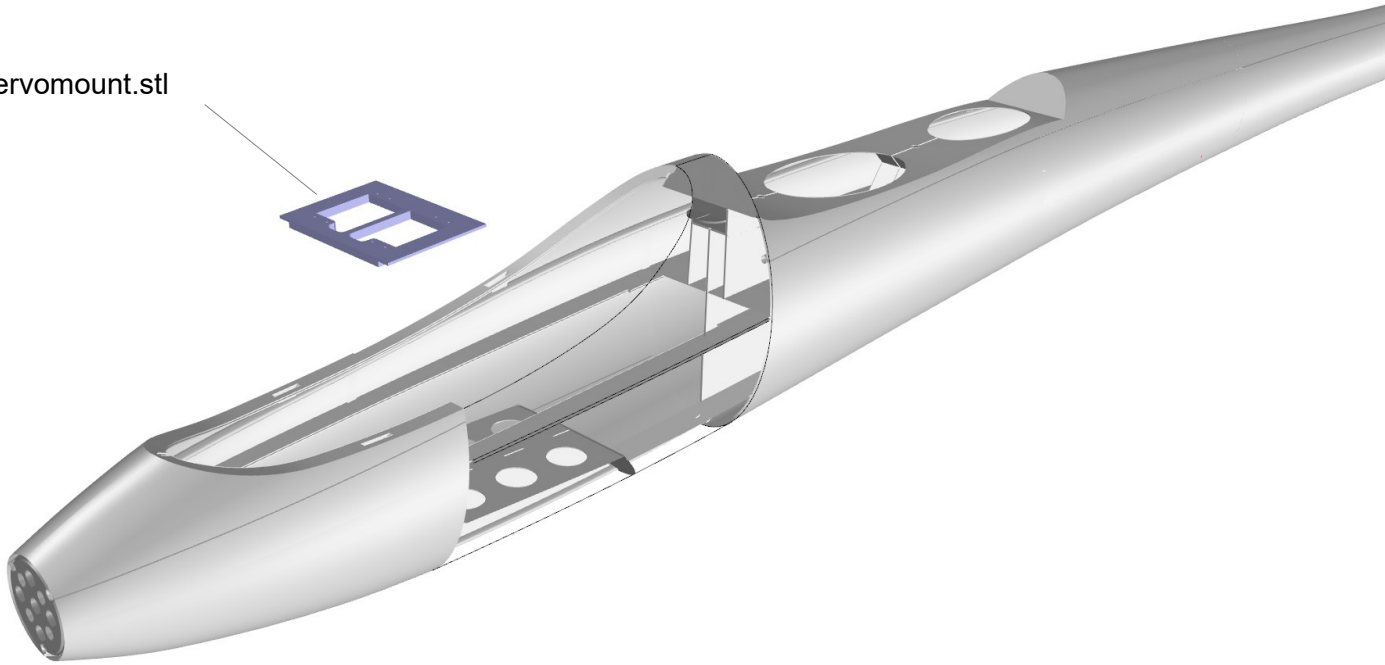

Push the servomount to the stop and use **CA-Glue**

Ø 28mm brushless-motor frontside installation - shown without cables

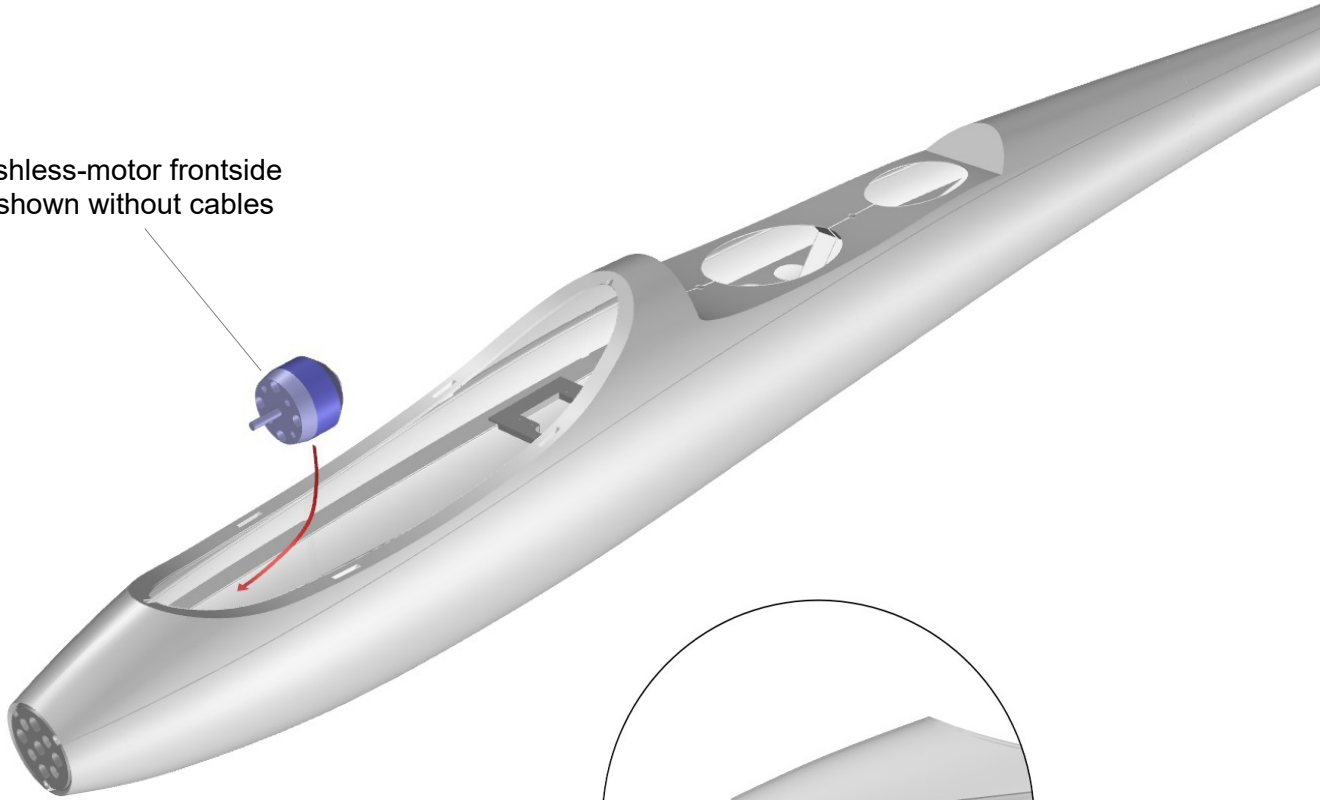

Motor-cables down

► *TRINITY* - electric power version



4 x M3 countersunk bolt

► *TRINITY* - glider version

TRINITY_fuselagenose.stl

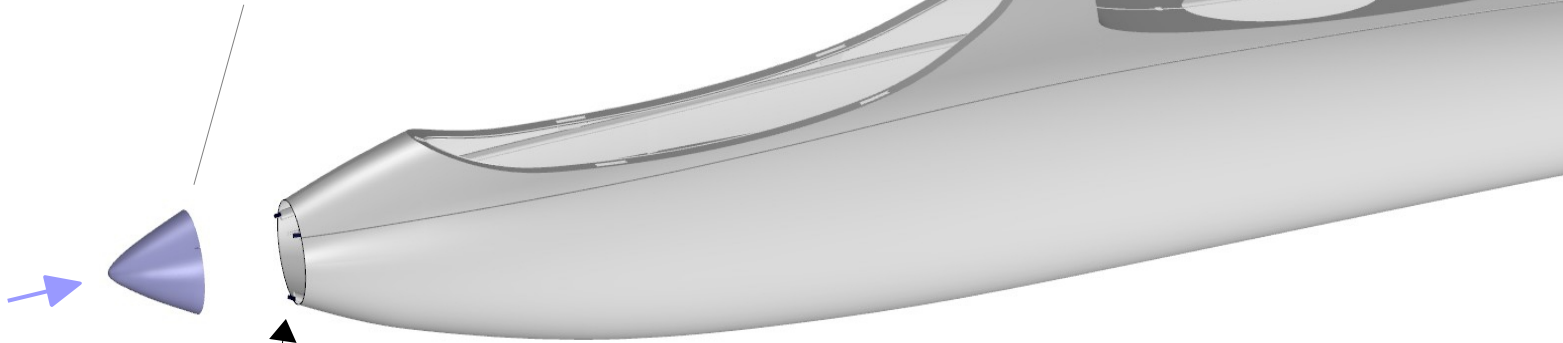

keep fuselage cfk-rods ca.
1,5mm overhanging for
better mounting and finally
CA-gluing of fuselage nose.
Nose seam at the bottom

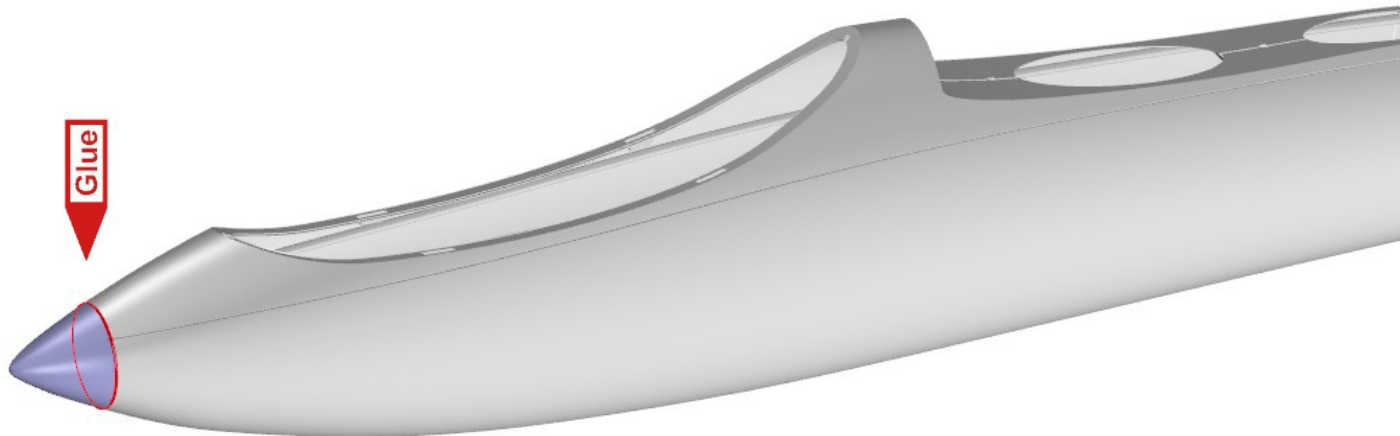
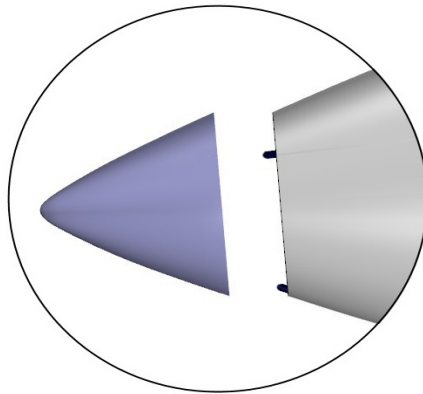

► Propeller and Spinner

TRINITY_spinner_PLA.stl, shown with back-fold rubber – or purchased Ø36mm spinner (TRINITY_spinner_LW-PLA.stl is optional)



Folding propeller 10 x 4" or similar
+ Aluminium center hub 34-35mm

► Assembly of RC components

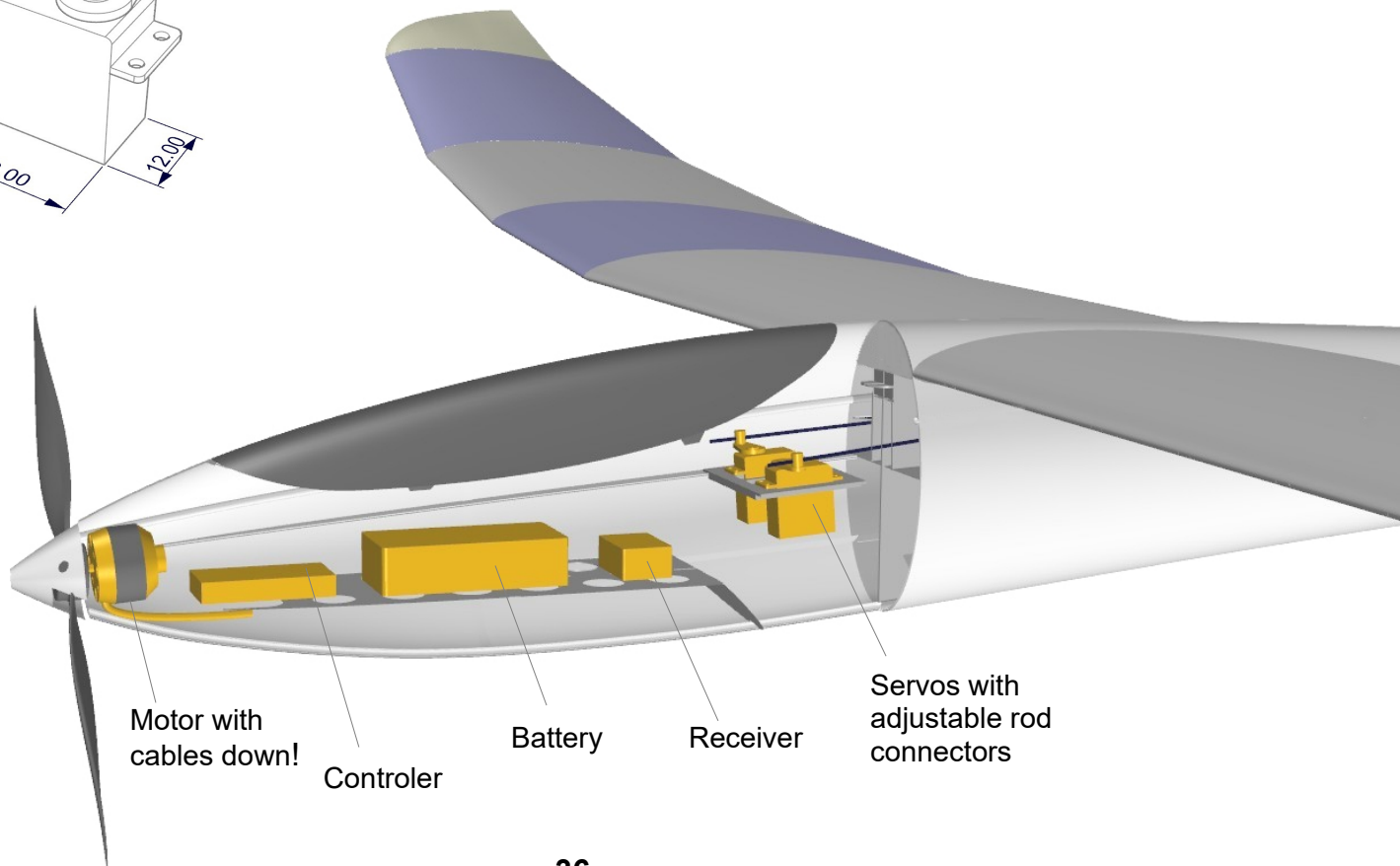
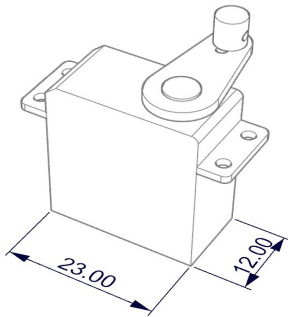

► Servo travel Setting

Before setting the servo travel, all control surfaces must be aligned correctly. The elevator is in neutral position when it is aligned to the fuselage elevator profile. Check if transmitter trim is in neutral position, and then adapt the length of the linkage from servoarm to control horn before setting the servo travel.

- Servo Travel:
- Elevator up / down - 15 – 20 mm at trailing edge
 - Rudder left / right - 35 – 45 mm at trailing edge

We recommend 25% Expo setting on Elevator and Rudder

► Center of Gravity

For good flying characteristics, it is very important to balance the new plane carefully. The Center of Gravity (CG) is 75mm behind the leading edge – you can find markings underneath the wing nearby the fuselage. For the first flights, please push the CG little more forward, just about 4 - 5mm.

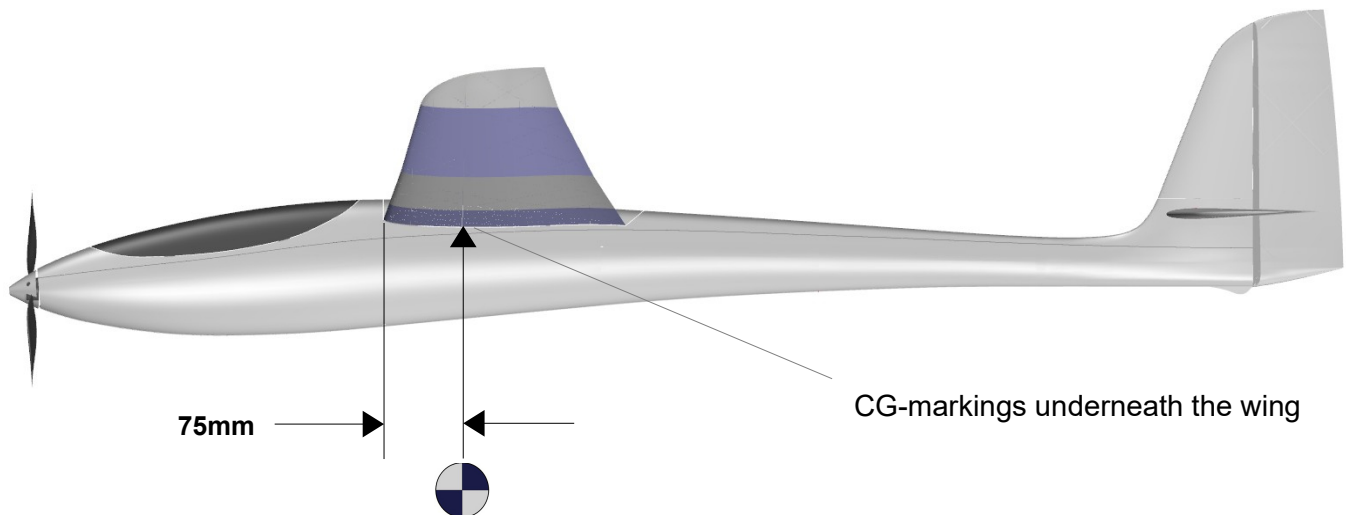

NOTICE: Take care not to keep One-Wall-printed planes in hot places like inside of heated-up cars or in direct intensive sun exposure – this will deform or even damage printed structures!!

► Safety Information

This current download data enables the user to print and build a 3D-printed RC model airplane.

A model like this is not a toy. It is not suitable and may not be operated by children under the age of 14 years.

The model and the associated accessories must be kept out of reach of children under 3 years. All electrical components, small parts and chemicals like glue etc. must also be kept out of reach of children

The only type of use of this model is the hobby sector. You as a user are fully responsible for safe operation. Take care not to endanger you or other people, nor to damage their property.

When operating your model, always stay in open country and keep far away from buildings, traffic, power lines and people.

Be aware that this model is controlled by a remote control, which is not safe from radio interference. In case of smallest indication of radio interference, operation of the model must immediately be stopped.

Avoid operating the model in bad weather conditions.

Ensure that you know and understand the instructions and warnings concerning this model airplane and any additional accessories like glues, tools, motors, propellers, all kind of rc-equipment, batteries, chargers etc.

Always ensure the model and the remote control are properly maintained and in good condition whenever you use it.

To operate the model, the batteries of the remote control and the model must be fully charged.

The transmitter must always kept switched on when the model is switched on First transmitter on, second receiver on – and reverse.

Always make complete function and range test before operating the model.

Operate the model only in good visibility and weather conditions.

Be aware, that in many countries third-party liability insurance is mandatory for operating (powered) model airplanes. Only operate your model in approved places.

Propellers of airplane models can cause injuries. As soon as the battery is connected, the area around the propeller must be kept clear including operators arms and hands.

Remove the battery after use and before disassembling the model.

Keep all parts dry, clean and avoid any water contact. Before you touch any part let it cool down if necessary.

Use the failsafe function of your remote control.

As we develop our 3D printed RC model planes as best as we can and as best of our experience, belief and knowledge, we do not accept liability for injuries and damage as a result of incorrect use